

STIGA®

Collecting series

MPV 320 W

MPV 520 W

Type FMC 112



TOSAERBA CON CONDUCENTE A BORDO SEDUTO
RIDE-ON LAWNMOWER WITH SEATED OPERATOR
TONEUSE À GAZON À CONDUCTEUR ASSIS
AUFSTZMÄHER (RASENMÄHER MIT FAHRERSITZ MIT SITZENDEM BENUTZER)
GRASMAIER MET ZITTENDE BEDIENER
CORTADORA DE PASTO CON CONDUCTOR SENTADO
PÄÄLTÄAJETTAVA RUOHONLEIKKURI
HAVETRAKTOR/HAVETRAKTOR MED FRONTKLIPPER (FM)
ÅKGRÄSKLIPPARE OCH FRÄMRE KLIPPNING (FM)
SEKAČKA SE SEDÍCI OBSLUHOV
ISTUVA JUHIGA MURUNITJA
SJEDEĆA KOSILICA TRAVE S OPERATEROM
VEZETŐÜLÉSES FŰNYÍRÓGÉP
BALNINÉ VEJAPJOVÉ SU SÉDINČIU OPERATORIUMI
SĚŽOT VADÁMA ZÁLIENU PĽAUJMAŠINA
SITTEGRESSKLIPPER
KOSIARKA Z OPERATOREM JADĄCYM, W POZYCJI SIEDZĄCEJ NA MASZYNE
CORTA-RELVAS PARA OPERADOR SENTADO
TRAKTORSKA KOSILNICA
TRAKTORSKA KOSAČICA (TRAKTORČIC)

MANUALE DI ISTRUZIONI IT
INSTRUCTION MANUAL EN
MANUEL D'UTILISATION FR
GEBRAUCHSANWEISUNG DE
GEBRUIKERSHANDLEIDINGNL NL
USO Y MANTENIMIENTO ES
KÄYTTÖOPAS FI
INSTRUKTIONSMANUAL DA
BRUKSANVISNING OCH UNDERHÅLL SV
INSTRUKTIONSMANUAL CS
KASUTUSJUHEND ET
PRIRUČNIK ZA UPORABU HR
HASZNÁLATI UTASÍTÁS HU
VARTOJIMO INSTRUKCIJA LT
OPERATORA ROKASGRĀMATA LV
BRUKSANVISNING - VEDLIKEHOLD NO
INSTRUKCJE OBSŁUGI PL
MANUAL DE USO PT
RUPRIROČNIK Z NAVODILI SL
PRIRUČNIK SA UPUTSTVIMA SR

pag.

13.....	MANUALE D'USO E MANUTENZIONE ISTRUZIONI ORIGINALI	IT
25.	OPERATING AND MAINTENANCE MANUAL Translation of the originals instructions	EN
37.....	NOTICE D'UTILISATION Traduction de la notice originale	FR
49	GEBRAUCHS- UND WARTUNGSANLEITUNG Aus der originalsprache übersetzte anleitung	DE
61.....	GEBRUIKSAANWIJZING Vertaling van de oorspronkelijke gebruiksaanwijzing	NL
73.....	MANUAL DEL OPERADOR Traducción del manual original	ES
85.....	KÄYTTÖ- JA HUOLTO-OPAS Alkuperäisten ohjeiden käännös	FI
97.....	BETJENINGSVEILEDNING Oversættelse af den originale brugsanvisning	DA
108.....	BRUKSANVISNING Översättning av original manual	SV
120.....	NÁVOD K POUŽITÍ A ÚDRŽBĚ překlad původního návodu k používání	CS
132.....	KASUTUS- JA HOOLDUSJUHEND Algupärased kasutusjuhendi tõlge	ET
144....	PRIRUČNIK ZA UPORABU I ODRŽAVANJE Prijevod originalnih uputa	HR
156...	HASZNÁLATI ÉS KARBANTARTÁSI KÉZIKÖNYV Eredeti használati utasítás fordítása	HU
168 ...	NAUDOJIMO IR TECHNINĖS PRIEŽIŪROS VADOVAS Originalių instrukcijų vertimas	LT
180....	LIETOŠANAS UN APKOPES ROKASGRĀMATA Instrukciju tulkojums no oriģināl valodas	LV

pag.

NO	BRUKER- OG VEDLIKEHOLDSHÅNDBOK ... 192 Oversettelse av den originale bruksanvisningen
PL	INSTRUKCJA OBSŁUGI I KONSERWACJI 204 Tłumaczenie instrukcji oryginalnej
PT	MANUAL DE UTILIZAÇÃO E MANUTENÇÃO ... 216 Tradução do manual original
SL	PRÍRUČKA NA POUŽITIE A ÚDRŽBU 228 Preklad originálneho návodu
SR	PRIRUČNIK ZA UPOTREBU I ODRŽAVANJE 240 Prijevod originalnih uputa

ILLUSTRAZIONI E SCHEMI	
ILLUSTRATIONS AND DIAGRAMS	
ILLUSTRATIONS ET SCHÉMAS	
ILLUSTRATIONEN UND PLÄNE	
ILLUSTRATIES EN DIAGRAMMEN	
ILUSTRACIONES Y ESQUEMAS	
KUVAT JA KAAVIOT	
DIAG RAMTEGNINGER	
ILLUSTRATIONER	
ILUSTRACE A SCHÉMATA	
ILLUSTRATSIOONID JA JOONISED	
ILUSTRACIJE I SCHEME	
ÁBRÁK ÉS RAJZOK	
ILIUSTRACIJOS IR SCHEMOS	
ATTĒLI UN SHĒMAS	
ILLUSTRASJONER OG SKJEMAER	
ILUSTRACJE I SCHEMATY	
FIGURAS E ESQUEMAS	
ILUSTRÁCIE A SCHÉMY	
ILUSTRACIJE I SKICE.....	252

**DICHIARAZIONE “CE” DI CONFORMITÀ
“EC” DECLARATION OF CONFORMITY
DECLARATION “CE” DE CONFORMITE
EG-KONFORMITÄTSEKTLÄRUNG
“EG”-VERKLARING VAN OVEREENSTEMMING
DECLARACION “CE” DE CONFORMIDAD
KONEIDEN EY-VAATIMUSTENMUKAISUUSVAKUUTUS
“EF”-OVERENSSTEMMELSESEKTLÆRINGEN
PRODUKTÖVERENSSTÄMMELSE ENLIGT FABRIKANTEN
„ES“ PROHLÁŠENÍ O SHODĚ
EUROOPA LIIDU VASTAVUSDEKLARATSIOON
IZJAVA O SUKLADNOSTI “CE”
„EK” MEGFELELŐSÉGI NYILATKOZAT
EB ATITIKTIES DEKLARACIJA
“EK” ATBILSTĪBAS DEKLARĀCIJA
EU-SAMSVARSERKLÆRING
DEKLARACJA ZGODNOŚCI „CE”
DECLARAÇÃO “CE” DE CONFORMIDADE
VYHLÁŠENIE „CE“ O ZHODE
CE IZJAVA O USKLAĐENOSTI**

Il fabbricante, the Manufacturer, le fabricant, der Hersteller,
de Fabrikant, el fabricante, valmistaja, Producenten, Tillverkaren, Výrobce, Tootja, Proizvođač,
A gyártó, Gamintojas, Ražotājs, Produzent, Producent, O fabricante, Výrobca, Proizvođač:

OFFICINE BIEFFEBI S.p.A.
Via dell'Artigianato, 7 - GONZAGA (MN) - ITALY

DICHIARA CHE LA MACCHINA
DESIGNAZIONEDELLAMACCHINA:RASAERBACONCONDUCENTESEUDOETAGLIOFRONTALE
CERTIFIES THAT THE MACHINE
DESIGNATION OFTHE MACHINE:FRONT CUTTINGLAWN MOWERWITH SEATED OPERATOR
CERTIFIE QUE LA MACHINE
DÉSIGNATION DE LA MACHINE: TONDEUSE AVEC CHAUFFEUR ASSIS ET COUPER AVANT
ERKLÄRT DASS DIE MASCHINE
BEZEICHNUNGDERMASCHINE:RASENMÄHERMITSITZENDEMBEDIENERUNDFRONTMÄHWERK
VERKLAART DAT DE MACHINE
AANWIJZINGVANDE MACHINE:GRASMAAIMACHINEMETAANZITTENDRIVERENFRONTALSNIJDEN
DECLARA QUE LA MÁQUINA
DESIGNACIÓNDELAMÁQUINA:CORTACÉSPEDCONCONDUCTORSENTADOYCORTEENFRENTE
VAKUUTTAA, ETTÄ KONE
KUNNAN KONEESTA: PÄÄLTÄAJETTAVA ETULEIKKAAVA RUOHONLEIKKURI
ERKLÆRER AT DENNE MASKINEN
UDPEGNING AF MASKINEN: PLÆNEKLIPPER MED DRIVER MØDET OG FRONTAL CUTTING
INTYGAR ATT MASKINEN
MASKINTYP: GRÄSKLIPPARER MED FÖRAREN SITTANDE OCH FRONTALA KAPNING

PROHLAŠUJE, ŽE STROJ
 OZNAČENÍ STROJE: **ZAHRADNÍ TRAKTOR S PŘEDNÍM SEČENÍM**
 DEKLAREERIB, ET MASIN
 MASINA KIRJELDUS **EESASUVA NIIDUSEADMEGA RAIDER**
 IZJAVLJUJE DA JE STROJ
 NAMJENA STROJA: **SJEDEČA KOSILICA TRAVE - RIDER S PREDNJOM KOSOM**
 KIJELENTI, HOGY A GÉP
 RENDELTETÉSE: **ELÖL VÁGÓ, VEZETŐULÉSES FŰNYÍRÓ TRAKTOR**
 PATVIRTINA, KAD MAŠINA
 MAŠINOS PASKIRTIS: **VEJOS PJOVIMO TRAKTORIUKAS SU PRIEKYJE SUMONTUOTU PJOVIMO AGREGATU**
 APLIECINA, KA MAŠINA
 MAŠINAS NOSAUKUMS: **ZĀLIENU PĻAUJMAŠĪNA AR VADĪTĀJA SĒDEKLI UN PRIEKŠPUSĒ**
UZSTĀDĪTU GRIEŠANAS MEHĀNISMU
 ERKLÆRER AT MASKINEN
 BETGNELSE PÅ MASKINEN. **GRESSKLIPPER MED FØRERSETTE OG FRONTKLIPPING**
 DEKLARUJE, ŽE MASZYNA
 OZNACZENIE MASZYNY: **KOSIARKA SAMOJEZDNA Z MIEJSCEM DLA OPERATORA Z PRZEDNIM**
AGREGATEM TNĄCYM
 DECLARA QUE A MÁQUINA
 DESIGNAÇÃO DA MÁQUINA: **CORTA RELVA FRONTAL COM CONDUTOR SENTADO**
 PREHLASUJE, ŽE STROJ
 OZNAČENIE STROJA **KOSAČKA SO SEDIACOU OBSLUHOU A ČELNÝM REZOM**
 IZJAVLJUJE DA JE MAŠINA
 OZNAKA MAŠINE: **KOSILICA SA SEDIŠTEM I SEČIVOM SA PREDNJE STRANE**

Marca, Brand, Marque, Marke, Merk, Marca, Merkki,
 Mærke, Fabrikat, Značka, Tootemark, Marka, Prekės ženklas,
 Preču zīme, Merke, Marka, Marca, Značka, Marka:STIGA

Modello, Model, Modèle, Modell, Model, Modelo, Malli, Type,
 Modell, Model, Mudel, Model, Model, Modell, Modelis,
 Modelis, Modell, Model, Modelo, Model, Model:

Numero di serie, Serial number, Numero de série, Seriennummer,
 Seriennummer, Numero de serie, Sarjanumero, Løbenummer,
 Seriennummer, Sériové číslo, Seerianumber, Serijski broj, Sorozatszám,
 Serijos numeris, Sērijas numurs, Seriennummer, Numer seryjny,
 Número de série, Sériové číslo, Broj serije:

Livello di potenza sonora misurato, Measured sound power level,
 Niveau de puissance sonore mesuré, Gemessener Schallleistungspegel,
 Gemeten niveau van geluidsvermogen, Nivel de potencia sonora medido,
 Mitattu äänitehtäso, Målt lydeffektniveau, Uppmått ljudeffektivä,
 Namērēnā ūroven ākustickēho vȳkonu, Mõõdetud helivõimsuse tase,
 Izmjerena razina zvučne snage, Mért zajtjeljesítmény szint,
 Išmatuotas garso galios lygis, Izmēritais skanas intensitātes līmenis,
 Målt lydeffektivä, Zmierzóny poziom mocy ākustycznej,
 Nivel medido de potencia sonora, Izmjerjen nivo zvočne moći,
 Izmereni nivo zvučne snage: 100 dB(A)

Livello di potenza sonora garantito, Guaranteed sound power level,
Niveau de puissance sonore garanti, Garantierter Schalleistungspegel,
Gegarandeerd niveau van geluidsvermogen, Nivel de potencia sonora garantizado,
Taattu äänitehotaso, Garanteret lydeffektniveau, Garanterad ljudeffektnivå,
Zaručena uroveň akustičkeho výkonu, Garanteeritud helivõimsuse tase,
Zajamčena razina zvučne snage, Garantált zajteljesítmény szint,
Užtikrinamas garso galios lygis, Garantētais skaņas intensitātes līmenis,
Garantert lydeffektnivå, Gwarantowany poziom mocy akustycznej,
Nível garantido de potência sonora, Zagotovljen nivo zvočne moči,
Garantovani nivo zvučne snage: 100 dB(A)

Ampiezza di taglio, Cutting width, Largeur de coupe, Schnittbreite, Snijbreedte,
Amplitud de corte, Leikkun laajuus, Klippebredde, Kljppbreddi, Sírka rezání, Lõikelaius,
Sirina rezanja, Vágási szélesség, Pjovimo plotis, Pļaušanas plātums, Klippebredde,
Szerokość cięcia, Amplitude de corte, Obseg košnje, Sirina košenja: 112 cm

IT E' CONFORME ALLE DISPOSIZIONI PERTINENTI DELLE SEGUENTI DIRETTIVE EUROPEE:

- Direttiva "Macchine" 2006/42/CE (e successive modifiche ed integrazioni) e alle disposizioni nazionali di attuazione (*).
(*) Procedura di valutazione della conformità: Allegato VIII
- Direttiva 2014/30/EU: requisiti essenziali di sicurezza e di salute relativi alla compatibilità elettromagnetica delle apparecchiature (e successive modifiche ed integrazioni).
- OND: 2000/14/EC, ANNEX VI - 2005/88/EC;
Ente certificatore: N°0197-TÜV Rheinland LGA Products GmbH Tillystrasse 2, 90431 Nürnberg – Germany;
Riferimento alle norme armonizzate:
 - EN ISO 5395-1:2013;
 - EN ISO 5395-3:2013/A1:2017;
 - EN 55012:2007/A1:2009
 - EN ISO 14982:2009
- Inoltre, si precisa che, il sottoscritto Ferrari Claudio in qualità di presidente della ditta "OFFICINE BIEFFEBI S.p.A." con sede in via dell' Artigianato 7, 46023, Gonzaga (Mn) - ITALY è il responsabile a costituire e a custodire il fascicolo tecnico.

EN CONFORMS TO THE PROVISIONS SET OUT IN THE FOLLOWING EUROPEAN DIRECTIVES:

- "Machinery" Directive 2006/42/EC (and subsequent modifications and updates) and the provisions for implementation within the ambit of national legislation (*).
(*) Conformity evaluation procedure: Attachment VIII
- Directive 2014/30/EU: essential health and safety requirements regarding electromagnetic compatibility of machinery (and subsequent modifications and updates).
- OND: 2000/14/EC, ANNEX VI - 2005/88/EC;
Certifying body: N°0197-TÜV Rheinland LGA Products GmbH Tillystrasse 2, 90431 Nürnberg – Germany;
With reference to the following harmonised standards:
 - EN ISO 5395-1:2013;
 - EN ISO 5395-3:2013/A1:2017;
 - EN 55012:2007/A1:2009
 - EN ISO 14982:2009
- Furthermore, it is hereby stated that Ferrari Claudio, as president of the company "OFFICINE BIEFFEBI S.p.A.", located in via dell' Artigianato 7, 46023, Gonzaga (Mn) - ITALY, is responsible for maintaining and safeguarding the technical file.

FR RÉPOND AUX EXIGENCES PRÉVUES PAR LES DIRECTIVES EUROPÉENNES:

- Directive sur les machines n°2006/42/CE (y compris ses amendements et rajouts) et ses mesures d'exécution nationale. (*)
(*) Procédure d'évaluation de la mise en conformité : annexe VIII
- Directive sur les machines n°2014/30/EU: Exigences essentielles en matière de protection et de santé sur la compatibilité électromagnétique (CEM) des équipements (ainsi que tout autre amendement et rajout).
- OND: 2000/14/EC, ANNEX VI - 2005/88/EC;
Organisme de certification : N°0197-TÜV Rheinland LGA Products GmbH Tillystrasse 2, 90431 Nürnberg – Germany;
Référence aux normes harmonisées:
 - EN ISO 5395-1:2013;
 - EN ISO 5395-3:2013/A1:2017;
 - EN 55012:2007/A1:2009
 - EN ISO 14982:2009
- En outre, il est stipulé que Claudio Ferrari, en qualité de Président et dépositaire du dossier technique de la société OFFICINE BIEFFEBI S.p.A. via dell' Artigianato 7, 46023, Gonzaga (Mn) - ITALIE est responsable de la rédaction et du suivi du manuel technique.

DEN EINSCHLÄGIGEN BESTIMMUNGEN DER FOLGENDEN EUROPÄISCHEN RICHTLINIEN ENTSPRICHT:

- Maschinenrichtlinie 2006/42/EG (und nachfolgende Änderungen und Ergänzungen) sowie den nationalen gesetzlichen Vorschriften zur Umsetzung der Richtlinie (*).
- (*) Konformitätsbewertungsverfahren: Anhang VIII
- Richtlinie 2014/30/EU: wesentliche sicherheits- und gesundheitsrelevante Anforderungen an die elektromagnetische Verträglichkeit der Geräte (und nachfolgende Änderungen und Ergänzungen).
- OND: 2000/14/EG, ANNEX VI - 2005/88/EG;
- Prüfstelle: N°0197-TÜV Rheinland LGA Products GmbH Tillystrasse 2, 90431 Nürnberg – Deutschland;
- Bezugnahme auf die harmonisierten Normen:
 - EN ISO 5395-1:2013;
 - EN ISO 5395-3:2013/A1:2017;
 - EN 55012:2007/A1:2009
 - EN ISO 14982:2009
- Zudem wird darauf hingewiesen, dass der Unterzeichnete Ferrari Claudio als Vorsitzender der Firma "OFFICINE BIEFFEBI S.p.A." mit Sitz in via dell' Artigianato 7, 46023, Gonzaga (Mn) - ITALIEN für die Erstellung und Aufbewahrung der technischen Unterlagen verantwortlich ist.

VOLDOET AAN DE VOLGENDE EUROPESE RICHTLIJNEN:

- Machine richtlijn 2006/42/CE (en de volgende wijzigingen en integraties) en de nationale uitvoeringsmaatregelen. (*)
- (*) Met inachtneming van evaluatieprocedure: bijlage VIII
- Machine richtlijn 2014/30/EU: Essentiële veiligheids- en gezondheidseisen van de elektromagnetische compatibiliteit van de uitrusting (en verdere wijzigingen en integraties).
- OND: 2000/14/EC, ANNEX VI - 2005/88/EC;
- Certificatie-instituut: N°0197-TÜV Rheinland LGA Products GmbH Tillystrasse 2, 90431 Nürnberg – Germany;
- Verwijzing naar de geharmoniseerde normen:
 - EN ISO 5395-1:2013;
 - EN ISO 5395-3:2013/A1:2017;
 - EN 55012:2007/A1:2009
 - EN ISO 14982:2009
- Voorts is bepaald dat Claudio Ferrari in de kwaliteit van de president en de bewaarder van het technisch dossier van Officine BIEFFEBI SpA Via dell' Artigianato 7, 46023, Gonzaga (Mn) - Italië verantwoordelijk is voor de productie en het naleven van de technische handleiding.

ES CONFORME A LAS DISPOSICIONES PERTINENTES DE LAS SIGUIENTES DIRECTIVAS EUROPEAS:

- Directiva "Máquinas" 2006/42/CE (y posteriores modificaciones e integraciones) y a las disposiciones nacionales de aplicación (*).
- (*) Procedimiento de valoración de la conformidad: Anexo VIII
- Directiva 2014/30/EU: requisitos esenciales de seguridad y de salud relativos a la compatibilidad electromagnética de los equipos (y posteriores modificaciones e integraciones).
- OND: 2000/14/EC, ANNEX VI - 2005/88/EC;
- Ente certificador: N°0197-TÜV Rheinland LGA Products GmbH Tillystrasse 2, 90431 Nürnberg – Germany;
- Referencia a las normas armonizadas:
 - EN ISO 5395-1:2013;
 - EN ISO 5395-3:2013/A1:2017;
 - EN 55012:2007/A1:2009
 - EN ISO 14982:2009
- Además, se precisa que el abajo firmante Ferrari Claudio, en calidad de presidente de la sociedad "OFFICINE BIEFFEBI S.p.A." con sede en via dell'Artigianato 7, 46023, Gonzaga (MN) - ITALIA, es el responsable de constituir y custodiar el expediente técnico.

ON SEURAAVIEN EUROOPPALAISTEN DIREKTIIVIN ASIAANKUULUVIEN SÄÄNNÖSTEN MUKAINEN:

- Konedirektiivi 2006/42/EY (ja seuraavat muutokset ja lisäykset) sekä kansalliset soveltamissäännökset (*).
- (*) Vaatimustenmukaisuuden arviointimenettely: Liite VIII
- Direktiivi 2014/30/EU: laitteiden sähkömagneettista yhteensopivuutta koskevat olennaiset turvallisuus- ja terveysvaatimukset (ja seuraavat muutokset ja lisäykset).
- OND: 2000/14/EY, LIITE VI - 2005/88/EY;
- Tarkastuslaitos: Nro 0197-TÜV Rheinland LGA Products GmbH Tillystrasse 2, 90431 Nürnberg – Germany;
- Viite yhdenmukaistettuihin standardeihin:
 - EN ISO 5395-1:2013
 - EN ISO 5395-3:2013/A1:2017;
 - EN 55012:2007/A1:2009
 - EN ISO 14982:2009
- Lisäksi ilmoitetaan, että allekirjoittanut Ferrari Claudio "OFFICINE BIEFFEBI S.p.A." (osoite Via dell' Artigianato 7, 46023, Gonzaga (Mn) - ITALIA) -yhtiön toimitusjohtajan ominaisuudessaan vastuussa teknisen asiakirja-aineiston laatimisesta ja säilyttämisestä.

ER I OVERENSSTEMMELSE MED FØLGENDE RELEVANTE EUROPÆISKE DIREKTIVER:

- Maskindirektiv 2006/42/CE (og yderligere tillæg) og nationale effektuerende mål. (*)
 - (*) Evalueringsprocedure: bilag VIII
 - Maskindirektiv 2014/30/EU: Afgørende sikkerheds- og sundhedskrav for materiellets elektromagnetiske kompatibilitet (og yderligere tillæg)
 - OND: 2000/14/EC, ANNEX VI - 2005/88/EC;
Certificeringsorgan: N°0197-TÜV Rheinland LGA Products GmbH Tillystrasse 2, 90431 Nürnberg – Germany;
- Henvielse til harmoniserede standarder:
- EN ISO 5395-1:2013;
 - EN ISO 5395-3:2013/A1:2017;
 - EN 55012:2007/A1:2009
 - EN ISO 14982:2009
- Endvidere er der stillet som betingelse at Claudio Ferrari i egenskab af direktør og depositar for den tekniske afdeling i firmaet OFFICINE BIEFFEBI S.p.A. via dell' Artigianato 7, 46023, Gonzaga (Mn) Italy er ansvarlig for < og opfølgningen af den tekniske vejledning.

ÖVERENSTÄMMER MED FÖLJANDE RELEVANTA EUROPEISKA DIREKTIV:

- Maskindirektiv 2006/42/CE (och ytterligare tillägg) och nationellt effektuerade mål. (*)
 - (*) Evalueringsprocedur: bilaga VIII
 - Maskindirektiv 2014/30/EU: Avgörande säkerhets- och hälsokrav för utrustningens elektromagnetiska kompatibilitet (och ytterligare tillägg)
 - OND: 2000/14/EC, ANNEX VI - 2005/88/EC;
Anmält organ: N°0197-TÜV Rheinland LGA Products GmbH Tillystrasse 2, 90431 Nürnberg – Germany;
- Hänvisning till harmoniserade standarder:
- EN ISO 5395-1:2013;
 - EN ISO 5395-3:2013/A1:2017;
 - EN 55012:2007/A1:2009
 - EN ISO 14982:2009
- Vidare är det så att Claudio Ferrari i egenskap av direktör för den tekniska avdelningen inom OFFICINE BIEFFEBI S.p.A. via dell' Artigianato 7, 46023, Gonzaga (Mn) Italien är ansvarig för produktion och uppföljning av tekniska manualer.

SPLŇUJE POŽADAVKY NÁSLEDUJÍCÍCH SMĚRNIC EU:

- Směrnice „O strojních zařízeních“ 2006/42/ES (ve znění pozdějších změn a doplňků) a národních prováděcích předpisů (*).
 - (*) Postup posuzování shody: Příloha VIII
 - Směrnice 2014/30/ES: základní požadavky týkající se bezpečnosti a ochrany zdraví a vztahující se k elektromagnetické kompatibilitě zařízení (ve znění pozdějších změn a doplňků).
 - OND: 2000/14/ES, PŘÍLOHA VI - 2005/88/ES;
- Certifikační orgán: N°0197-TÜV Rheinland LGA Products GmbH Tillystrasse 2, 90431 Nürnberg – Germany;
- Odkaz na harmonizované normy:**
- EN ISO 5395-1:2013;
 - EN ISO 5395-3:2013/A1:2017;
 - EN 55012:2007/A1:2009
 - EN ISO 14982:2009
- Kromě toho dodáváme, že níže podepsaný Claudio Ferrari jako prezident firmy „OFFICINE BIEFFEBI S.p.A.“, se sídlem via dell' Artigianato 7, 46023, Gonzaga (Mn) - ITÁLIE, je odpovědný za zpracování a uchování technické dokumentace.

VASTAB JÄRGMISTE EUROOPA LIIDU DIREKTIIVIDE ASJAKOHASTELE NÕUETELE:

- masinate direktiiv 2006/42/EÜ (koos hilisemate muudatuste ja täiendustega) ning selle riigisisesed rakendussätted (*).
 - (*) Vastavushindamise menetlus: VIII lisa
 - direktiiv 2014/30/EL: seadmete elektromagnetilise ühilduvusega seotud olulised turvalisus- ja ohutusnõuded (ning nende hilisemad muudatused ja täiendused).
 - välitingimustes kasutatavate seadmete määra: 2000/14/EÜ, VI LISA – 2005/88/EÜ;
- Kinnitav asutus: N°0197-TÜV Rheinland LGA Products GmbH Tillystrasse 2, 90431 Nürnberg – Germany;
- harmoneeritud standardid:
- EN ISO 5395-1:2013;
 - EN ISO 5395-3:2013/A1:2017;
 - EN 55012:2007/A1:2009;
 - EN ISO 14982:2009;
- tehnilise dokumentatsiooni koostamise ja hoidmise eest vastutab allkirjutanu Ferrari Claudio, äriühingu OFFICINE BIEFFEBI S.p.A. (aadressiga via dell' Artigianato 7, 46023, Gonzaga (Mn) - ITAALIA) nõukogu esimees.

U SKLADU S ODREDBAMA SLJEDEĆIH EUROPSKIH DIREKTIVA:

HR

- Direktive “o strojevima” 2006/42/EZ (i njezinih izmjena i dopuna) te nacionalnih provedbenih odredbi (*).
- (*) Postupak ocjene sukladnosti: Prilog VIII.
- Direktive 2014/30/EU: bitni zahtjevi u vezi sigurnosti i zdravlja što se tiče elektromagnetske kompatibilnosti opreme (i njezinih izmjena i dopuna).
- Direktive o buci u okolišu uzrokovane opremom za uporabu na otvorenom (OND): 2000/14/EZ, DODATAK VI. - 2005/88/EZ;

Sukladnost s usklađenim normama:

- EN ISO 5395-1:2013;
- EN ISO 5395-3:2013/A1:2017;
- EN 55012:2007/A1:2009
- EN ISO 14982:2009
- Osim toga, izjavljujemo da je dolje potpisani Ferrari Claudio, kao predsjednik tvrtke “OFFICINE BIEFFEBI S.p.A.” sa sjedištem u via dell’Artigianato 7, 46023, Gonzaga (Mn) - ITALIJA, odgovorna osoba za sastavljanje i čuvanje tehničke dokumentacije.

MEGFELEL AZ ALÁBBI EURÓPAI IRÁNYELVEKBEK FOGLALT RENDELKEZÉSEKNEK:

HU

- (többször módosított és kiegészített) 2006/42/EK Gépekről szóló irányelv, valamint annak nemzeti végrehajtási rendeletei (*).
- (*) Megfelelőség értékelési eljárás: VIII. melléklet
- 2014/30/EU irányelv: az elektromágneses összeférhetőségre vonatkozó alapvető biztonsági és egészségügyi követelmények (valamint módosításai és kiegészítései).
- OND: 2000/14/EK, VI. MELLÉKLET - 2005/88/EK;
- Tanúsított szerv: N°0197-TÜV Rheinland LGA Products GmbH Tillystrasse 2, 90431 Nürnberg – Germany;

Harmonizált jogszabályok:

- EN ISO 5395-1:2013;
- EN ISO 5395-3:2013/A1:2017;
- EN ISO 55012:2007/A1:2009;
- EN ISO 14982:2009;
- Kijelentjük továbbá, hogy alulírott Ferrari Claudio mint az „OFFICINE BIEFFEBI S.p.A.” cég elnöke – székhelye 46023, Gonzaga (Mn) via dell’Artigianato 7, OLASZORSZÁG – felelős a műszaki dokumentáció összeállításáért és őrzéséért.

ATITINKA ŠIŲ EUROPOS SĄJUNGOS DIREKTYVŲ ATITINKAMAS NUOSTATAS:

LT

- Mašinių direktyvos 2006/42/EB (su pakeitimais ir papildymais) ir nacionalinių lygiu igyvendinamų nuostatų (*).
- (*) Atitikties įvertinimo procedūra: VIII priedas
- Direktyvos 2014/30/ES: saugos ir sveikatos esminius reikalavimus, susijusius su įrenginių elektromagnetiniu suderinamumu (su pakeitimais ir papildymais).
- Skleidžiamo triukšmo standartų: 2000/14/EB, VI PRIEDAS – 2005/88/EB;
- Sertifikavimo įstaiga: N°0197-TÜV Rheinland LGA Products GmbH Tillystrasse 2, 90431 Nürnberg – Germany;

Nuoroda į darniuosius standartus:

- EN ISO 5395-1:2013;
- EN ISO 5395-3:2013/A1:2017;
- EN 55012:2007/A1:2009
- EN ISO 14982:2009
- Taip pat patvirtinama, kad, toliau pasirašiusysis Claudio Ferrari, veikiantis kaip bendrovės „OFFICINE BIEFFEBI S.p.A.“, esančios via dell’Artigianato 7, 46023, Goncagoje (Mn), Italijoje, direktorius yra atsakingas už techninės bylos sudarymą ir saugojimą.

SASKAŅĀ AR ŠĀDU EIROPAS DIREKTĪVU NOTEIKUMIEM:

LV

- Direktīvu “parmašīnām” 2006/42/EK (arturpmākiemgrozijumiem un papildinājumiem) un attiecīgās valsts likumdošanas aktiem (*).
- (*) Atbilstības novērtēšanas procedūra: VIII pielikums
- Direktīvu 2014/30/ES: veselības un drošības pamatprasības attiecībā uz iekārtu elektromagnētisko savietojamību (ar turpmākiem grozijumiem un papildinājumiem).
- OND: 2000/14/EK, VI PIELIKUMS - 2005/88/EK;
- Sertifikācijas iestāde: N°0197-TÜV Rheinland LGA Products GmbH Tillystrasse 2, 90431 Nürnberg – Germany;

Atsauce uz saskaņotajiem standartiem:

- EN ISO 5395-1:2013;
- EN ISO 5395-3:2013/A1:2017;
- EN 55012:2007/A1:2009
- EN ISO 14982:2009
- Turklāt, tiek precizēts, ka apakšā parakstījis Ferrari Claudio kā uzņēmuma “OFFICINE BIEFFEBI S.p.A.”, kas atrodas via dell’Artigianato 7, 46023, Gonzaga (Mn) - ITALIJA priekšsēdētājs, ir atbildīgs par tehniskās dokumentācijas sastādīšanu un uzglabāšanu.

ER I SAMSVAR MED DE RELEVANTE BESTEMMELSENE I FØLGENDE STANDARDER:

- Maskindirektiv 2006/42/CE (og etterfølgende endringer og tillegg) og gjeldende nasjonale disposisjoner (*).
 - (*) Vurderingsprosedyre for samsvar: Vedlegg VIII
 - Direktiv 2014/30/EU: grunnleggende krav til sikkerhet og helse i forbindelse med elektromagnetisk kompatibilitet av utstyr (og etterfølgende endringer og tillegg).
 - OND: 2000/14/EC, ANNEX VI - 2005/88/EC;
 - Sertifiseringsorgan: N°0197-TÜV Rheinland LGA Products GmbH Tillystrasse 2, 90431 Nürnberg – Germany;
- Referanse til harmoniserte normer:
- EN ISO 5395-1:2013;
 - EN ISO 5395-3:2013/A1:2017;
 - EN 55012:2007/A1:2009
 - EN ISO 14982:2009
- I tillegg er det fastsatt at undertegnede, Claudio Ferrari som administrerende direktør av "WORKSHOP BIEFFEBI S.p.A.» med hovedsete i Artigianato 7, 46023, Gonzaga (Mn) - ITALIA, er ansvarlig for å utarbeide og oppbevare den tekniske dokumentasjonen.

JEST ZGODNA Z NASTĘPUJĄCYMI DYREKTYWAMI EUROPEJSKIMI:

- **Dyrektywamaszynową2006/42/WE (wrazz późniejszymi zmianami i uzupełnieniami) i krajowymi przepisami wykonawczymi (*)**.
 - (*) **Procedura oceny zgodności: Załącznik VIII**
 - **Dyrektywa 2014/30/UE: w sprawie harmonizacji ustawodawstw państw członkowskich odnoszących się do kompatybilności elektromagnetycznej (wraz z późniejszymi zmianami i uzupełnieniami)**.
 - **OND: 2000/14/WE, ZAŁĄCZNIK VI - 2005/88/WE;**
 - **Jednostka certyfikująca: N°0197-TÜV Rheinland LGA Products GmbH Tillystrasse 2, 90431 Nürnberg – Germany;**
- Odniesienie do norm zharmonizowanych:**
- **EN ISO 5395-1:2013;**
 - **EN ISO 5395-3:2013/A1:2017;**
 - **EN 55012:2007/A1:2009**
 - **EN ISO 14982:2009**
- Ponadto wskazuje się, że niżej podpisany Ferrari Claudio, jako prezes spółki „OFFICINE BIEFFEBI S.p.A.”, z siedzibą pod adresem via dell' Artigianato 7, 46023, Gonzaga (Mn) - ITALY, jest odpowiedzialny za sporządzenie i przechowywanie dokumentacji technicznej.

ESTÁ CONFORME COM AS NORMAS PERTINENTES DAS SEGUINTES DIRETIVAS EUROPEIAS:

- Diretiva “Máquinas” 2006/42/CE (e posteriores alterações e aditamentos) e normas nacionais de execução (*).
 - (*) Procedimento de avaliação da conformidade: Anexo VIII
 - Diretiva 2014/30/UE: requisitos essenciais de segurança e saúde relativos à compatibilidade eletromagnética dos aparelhos (e posteriores alterações e aditamentos).
 - OND: 2000/14/CE, ANEXO VI - 2005/88/CE;
 - Órgão certificador: N°0197-TÜV Rheinland LGA Products GmbH Tillystrasse 2, 90431 Nürnberg – Germany;
- Referência às normas harmonizadas:
- EN ISO 5395-1:2013;
 - EN ISO 5395-3:2013/A1:2017;
 - EN 55012:2007/A1:2009
 - EN ISO 14982:2009
- Informa-se que Ferrari Claudio, abaixo-assinado na qualidade de diretor-geral da empresa “OFFICINE BIEFFEBI S.p.A.”, com sede em via dell' Artigianato 7, 46023, Gonzaga (Mn) - ITALY, é responsável pela elaboração e conservação de toda a documentação técnica.

SA ZHODUJE S NARIADENIAMI VYPLÝVAJÚCIMI Z NASLEDOVNÝCH EURÓPSKÝCH SMERNÍC

- **Smernice „Stroje“ 2006/42/ES (v znení neskorších úprav a doplnkov) a vnútroštátnych vyhlášok (*)** **Proces posudzovania zhody Príloha**
 - **Smernica 2014/30/EÚ: základné požiadavky na bezpečnosť a ochranu zdravia v oblasti elektromagnetickej kompatibility zariadení (v znení neskorších úprav a doplnkov)**.
 - **OND: 2000/14/EC, ANNEX VI - 2005/88/EC;**
 - **Ustanova, ki izda potrdilo: N°0197-TÜV Rheinland LGA Products GmbH Tillystrasse 2, 90431 Nürnberg – Germany;**
- ref. harmonizované normy:**
- **EN ISO 5395-1:2013;**
 - **EN ISO 5395-3:2013/A1:2017;**
 - **EN 55012:2007/A1:2009**
 - **EN ISO 14982:2009**
- Dalej sa špecifikuje, že dolupodpisany Claudio Ferrari ako prezident firmy „OFFICINE BIEFFEBI a.s.“ sídljacej na adrese via dell' Artigianato 7, 46023, Gonzaga (Mn) – Taliansko zodpovedá za zriadenie a uchovávanie technickej knižky

U SKLADU JE SA EVROPSKIM ODREDBAMA KOJE SLEDE:

- Odredba „Mašine” 2006/42/CE (i naknadne izmene i dopune) i nacionalne odredbe (*).
- (*) Procedura za procenu usklađenosti: U prilogu VIII
- Odredba 2014/30/EU: osnovni uslovi bezbednosti i zdravlja vezani za elektromagnetnu kompatibilnost aparata (i naknadne izmene i dopune).

— **OND: 2000/14/EC, ANEKS VI - 2005/88/EC;**

Sertifikaciono telo: N°0197-TÜV Rheinland LGA Products GmbH Tillystrasse 2, 90431 Nürnberg – Germany;

Upućivanje na usklađene norme:

— EN ISO 5395-1:2013;

— EN ISO 5395-3:2013/A1:2017;

— EN 55012:2007/A1:2009

— EN ISO 14982:2009

- Pored toga, precizira se da dolepotpisani Ferari Claudio, direktor firme „OFFICINE BIEFFEBI S.p.A.” sa sedištem u via dell’ Artigianato 7, 46023, Gonzaga (Mn) - ITALIJA je odgovorno lice za izradu i čuvanje tehničke brošure.

Fatto a - Made in - Fait à - Hergestellt in - Fabricado en

Made in - Gefabriceert in - Valmistettu - Tillverkad i

Sepsáno v - Sastavljeno u - Készült - Sudaryta - Sastādīts

Utført i - Sporządzono w - Feito em - Miesto - Mesto

GONZAGA (MN) ITALY

li - on - le - den - en fecha - Den - Op

Päiväys - Den - v - dana - Dátum - datums

dato - dnia - aos - dña -

.....

FERRARI CLAUDIO

PRESIDENT OF

OFFICINE BIEFFEBI S.P.A.

Firma - Signature - Signature - Unterschrift - Firma
Underskrift - Handtekening - Allekirjoitus - Namnteckning
Podpis - Allkirj - Potpis - Aláírás - Parašas - Paraksts
Underskrift - Podpis - Emoresa - Podpis - Potpis



ILLUSTRAZIONI E SCHEMI
ILLUSTRATIONS AND DIAGRAMS
ILLUSTRATIONS ET SCHÉMAS
BILDER UND ZEICHNUNGEN
ILLUSTRATIES EN DIAGRAMMEN
ILUSTRACIONES Y ESQUEMAS
VAROITUSTARRAT JA KUVAT
DIAGRAMTEGNINGER
ILLUSTRATIONER
ILUSTRACE A SCHÉMATA
ILLUSTRATSIOONID JA JOONISED
ILUSTRACIJE I SHEME
ÁBRÁK ÉS RAJZOK
ILIUSTRACIJOS IR SCHEMOS
ATTĒLI UN SHĒMAS
ILLUSTRASJONER OG SKJEMAER
ILUSTRACJE I SCHEMATY
FIGURAS E ESQUEMAS
ILUSTRÁCIE A SCHÉMY
ILUSTRACIJE I SKICE

0.

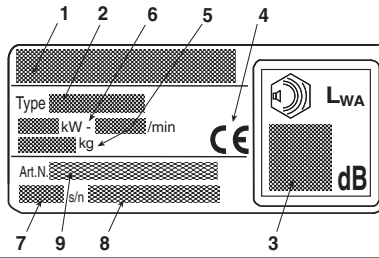

1.

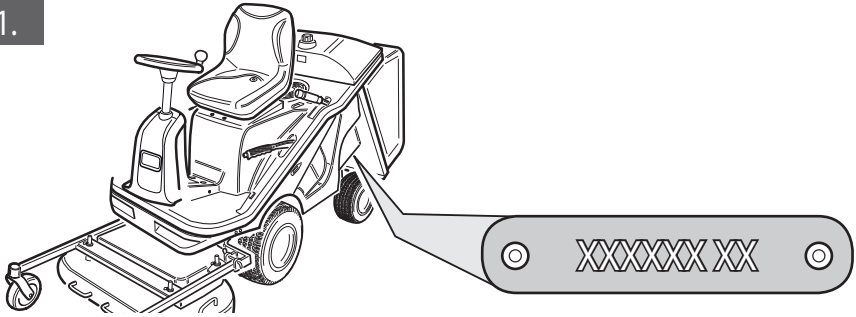

6.1

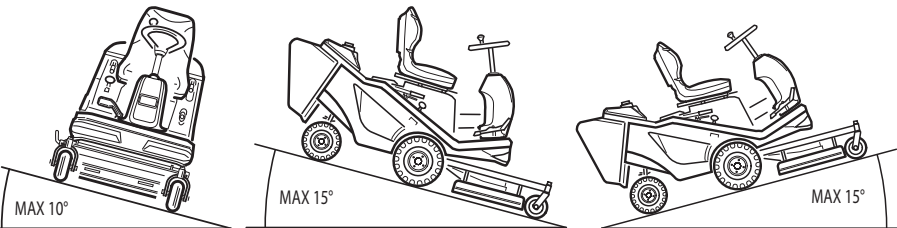

6.2

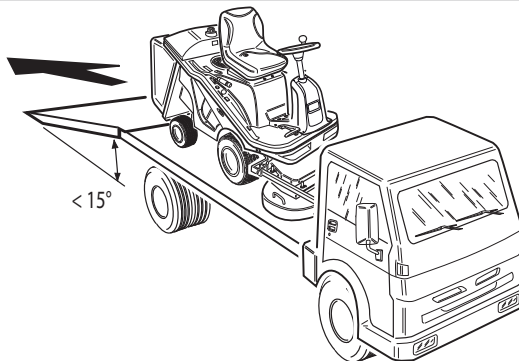

7.

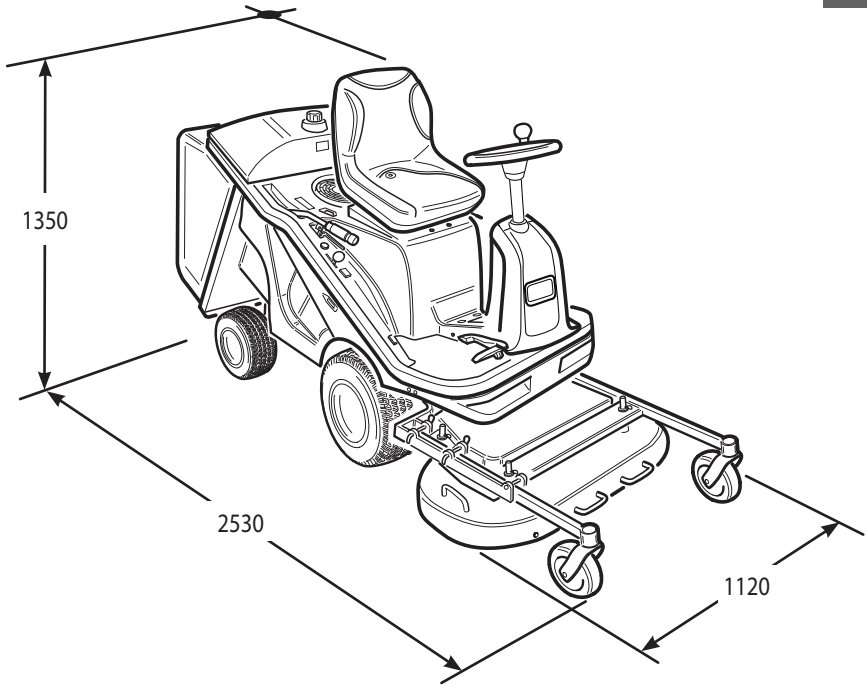

8.

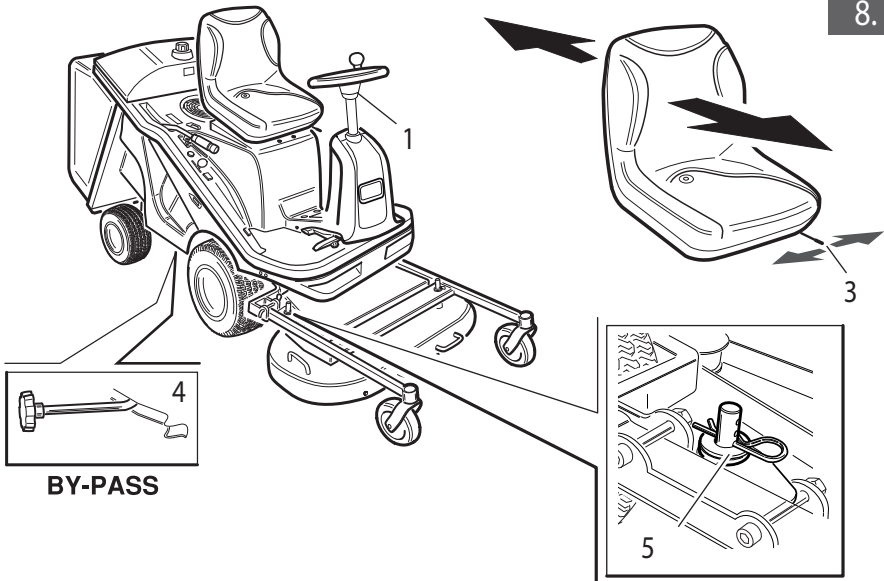

8.

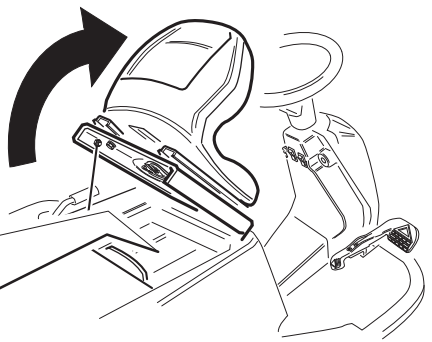
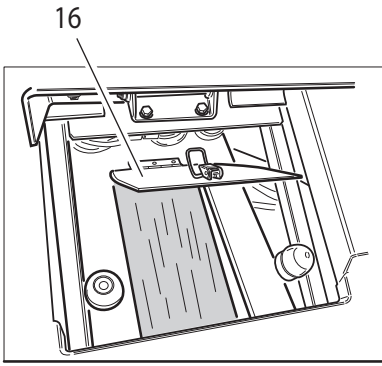
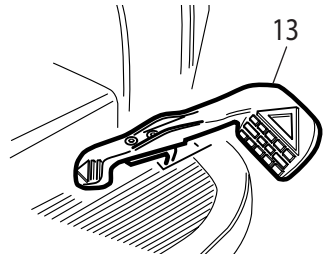
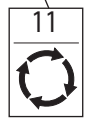
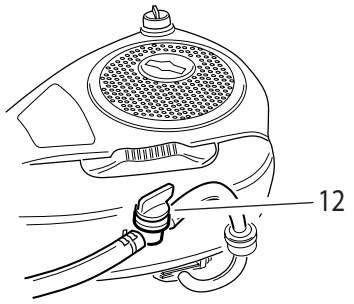
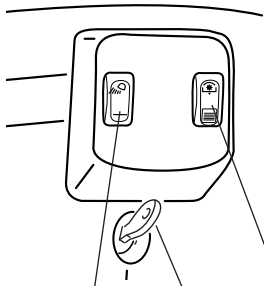
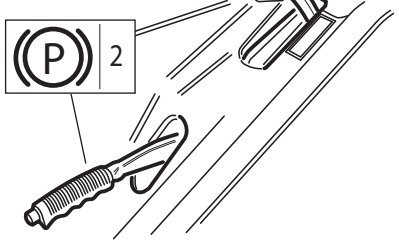
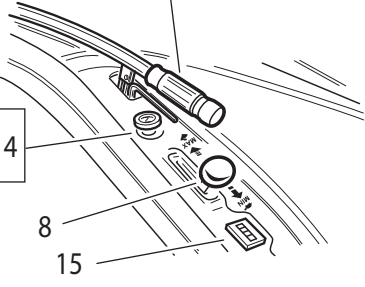

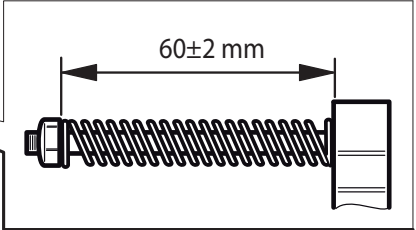
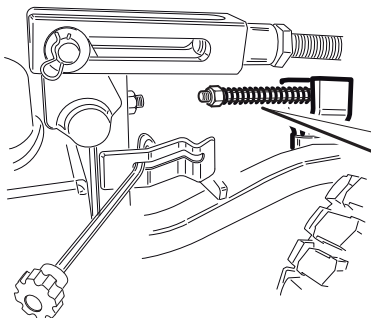
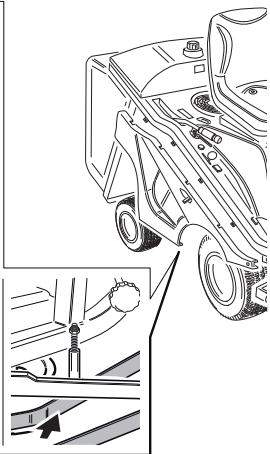
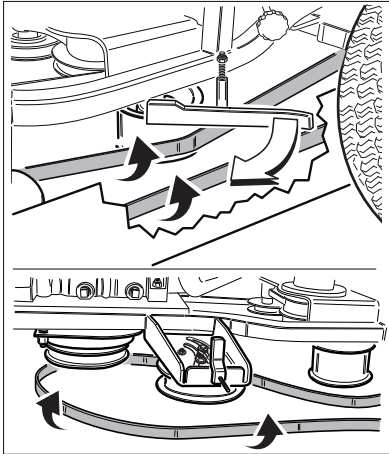
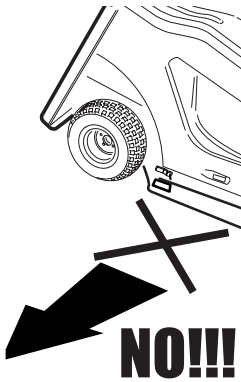
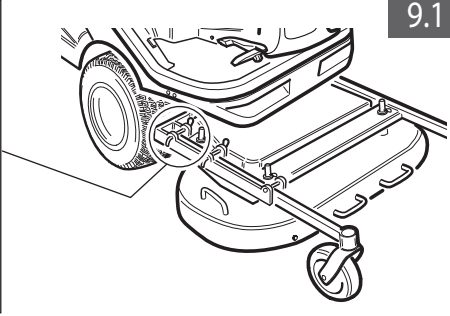
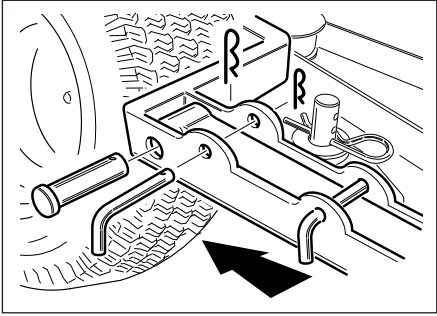

9.2

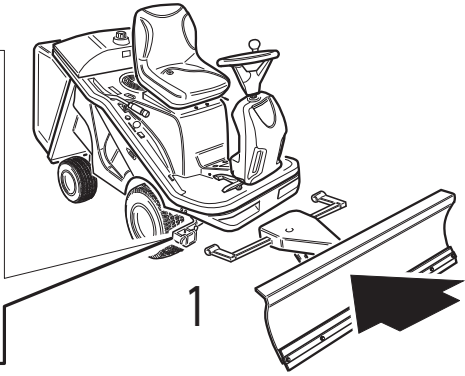
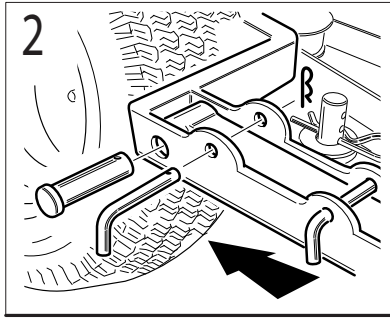

9.3

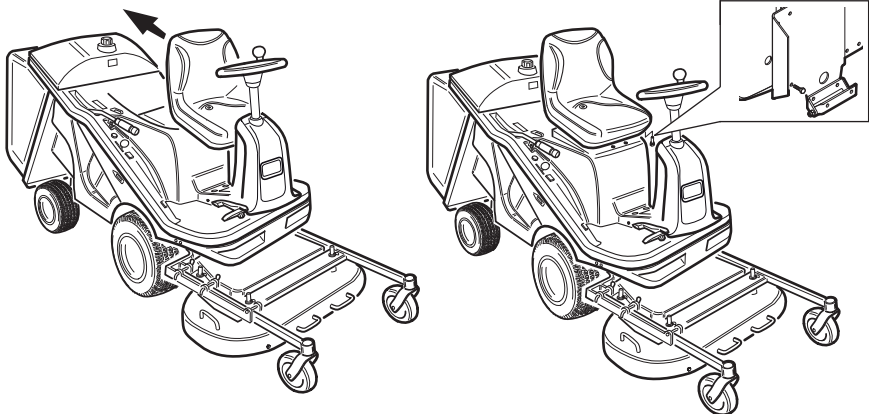
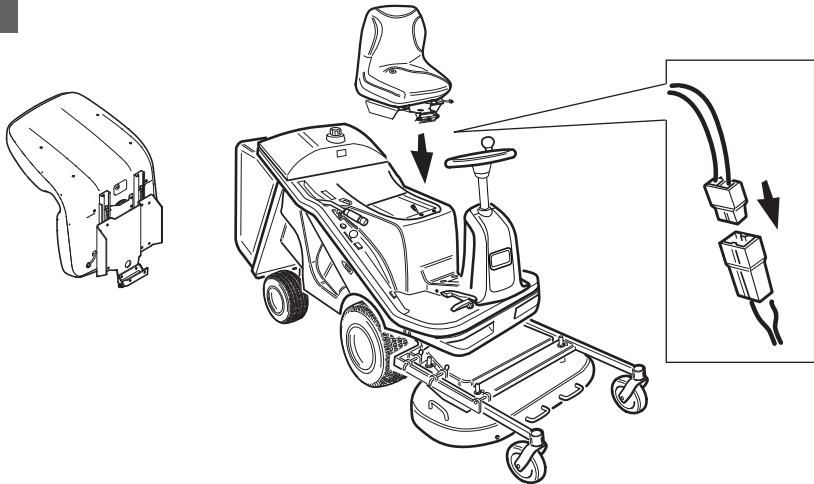

10.1

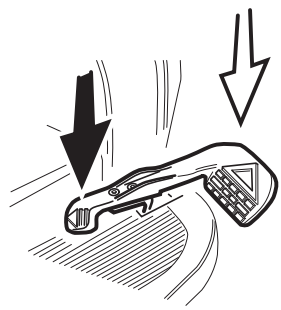
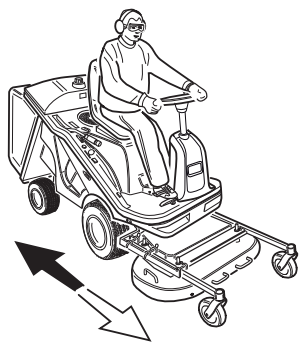

10.2

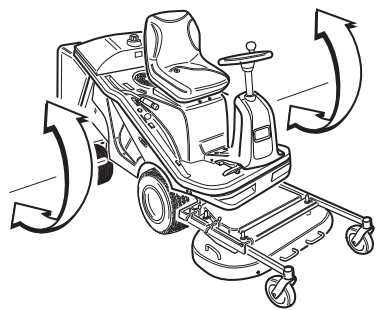
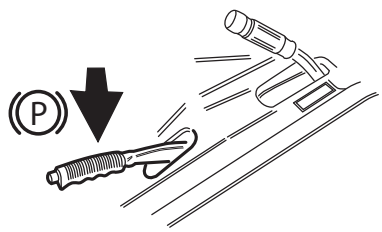
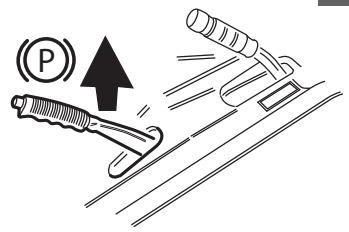
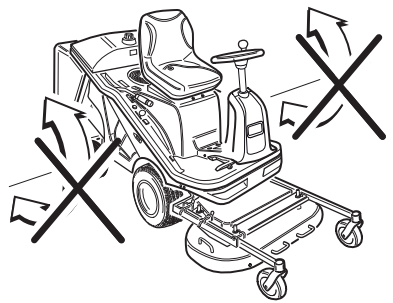

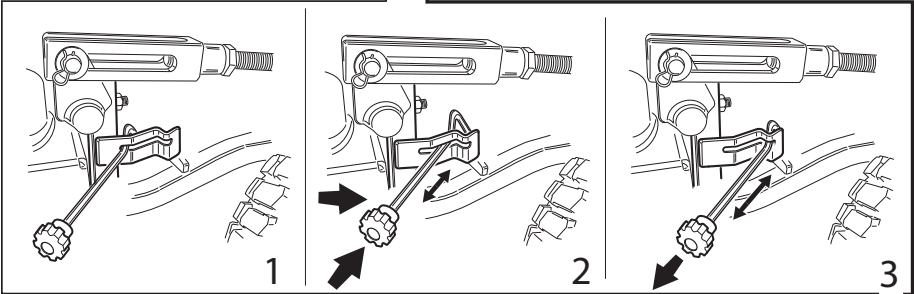
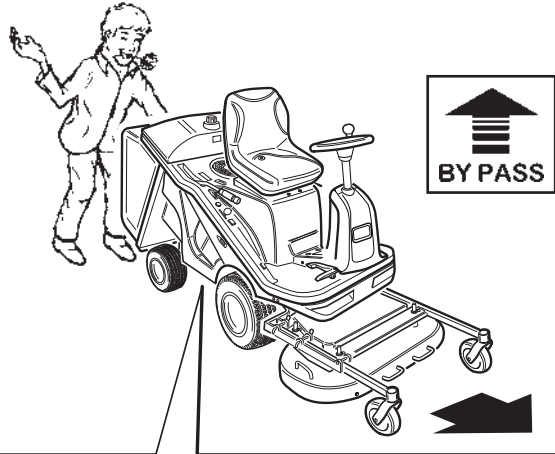
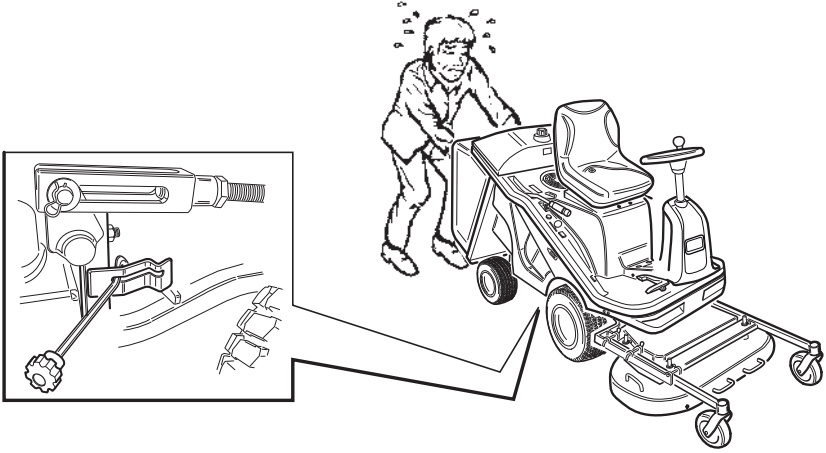

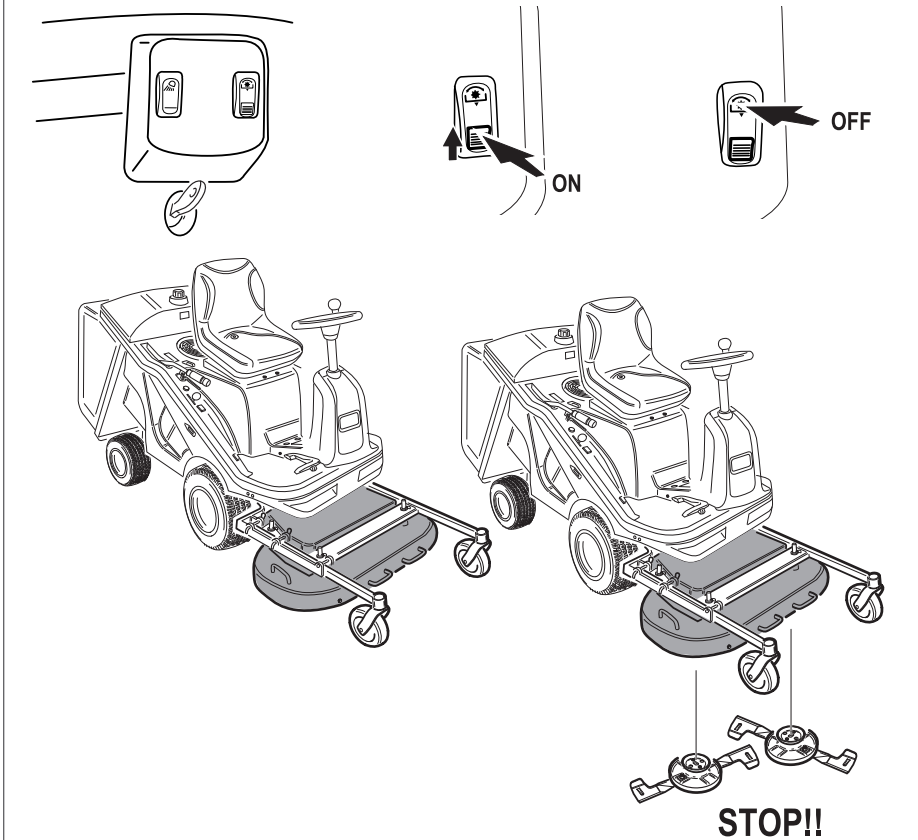
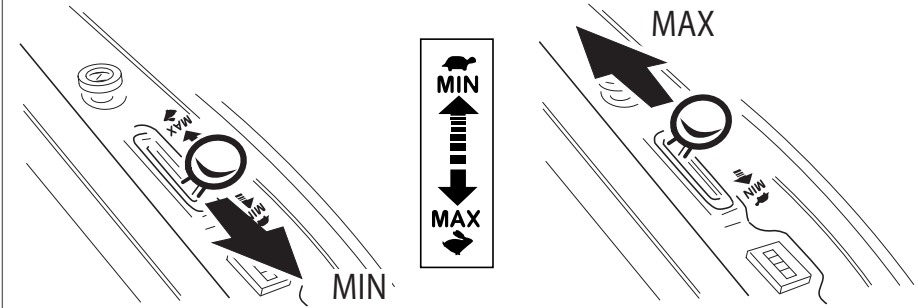

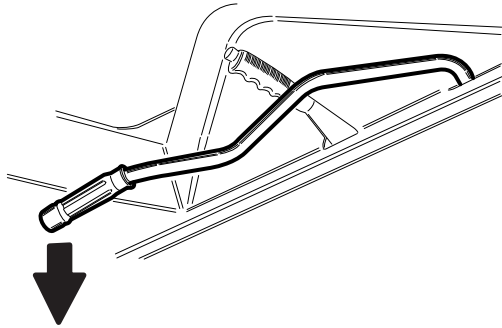
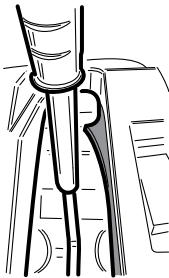
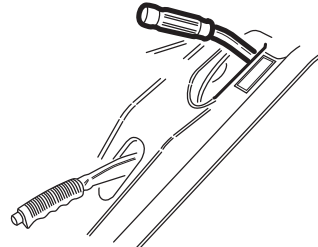
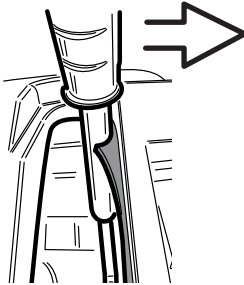
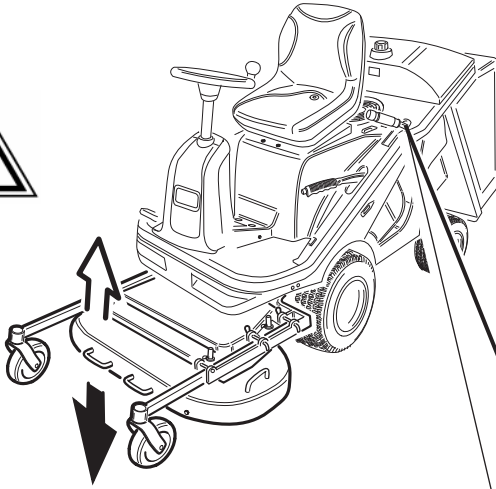

10.7

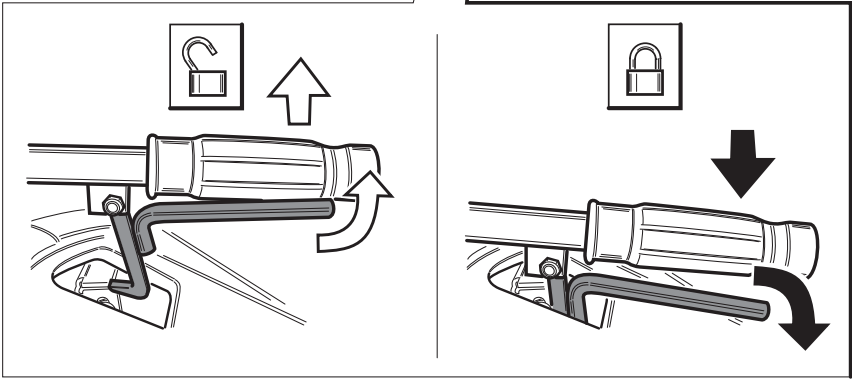
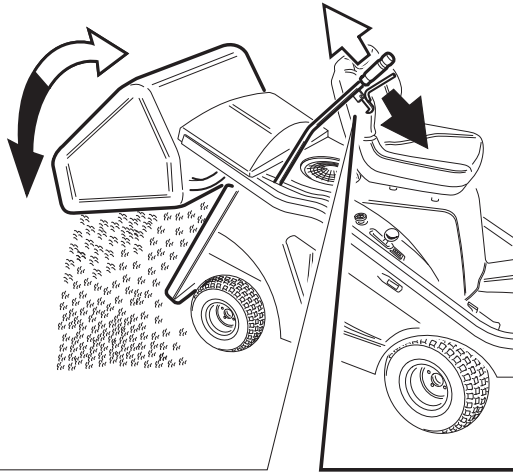

10.8

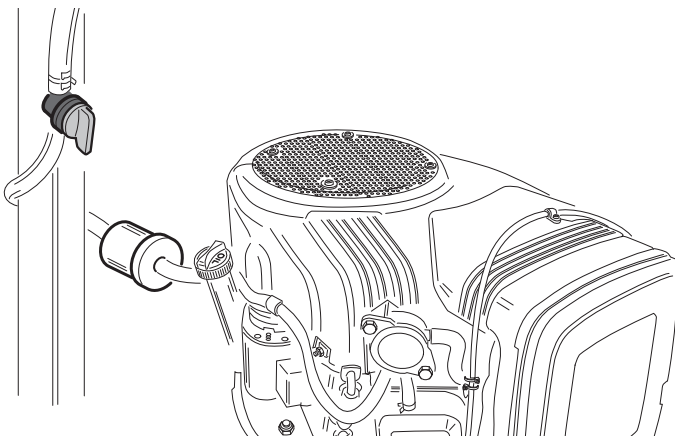

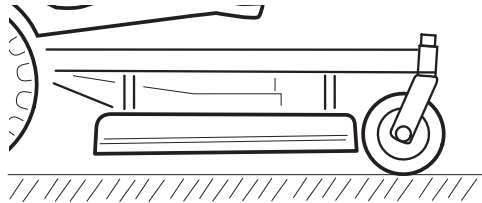
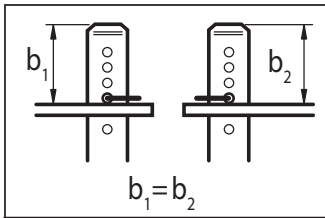
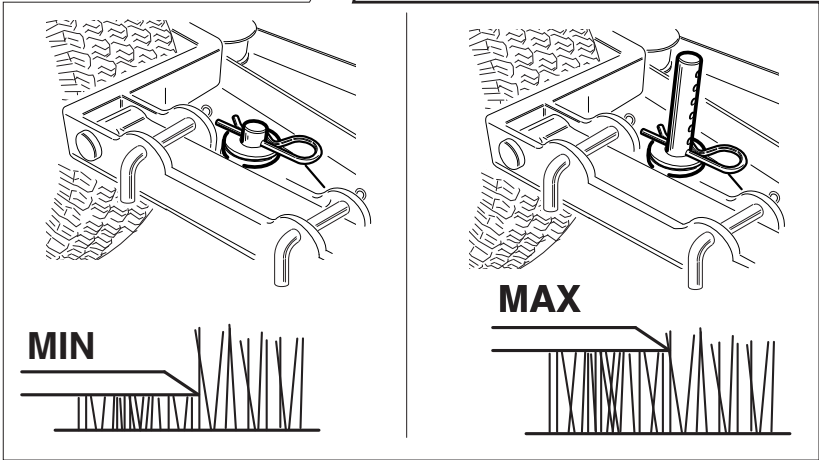
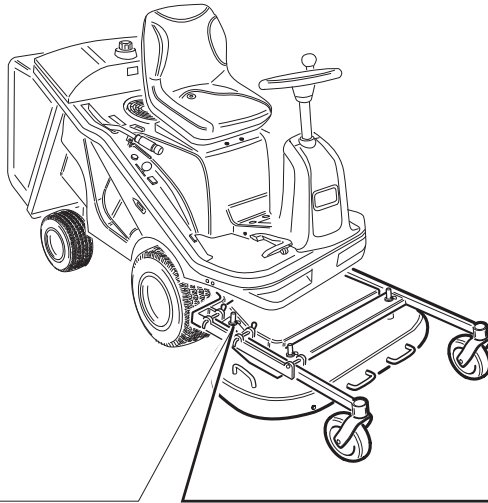

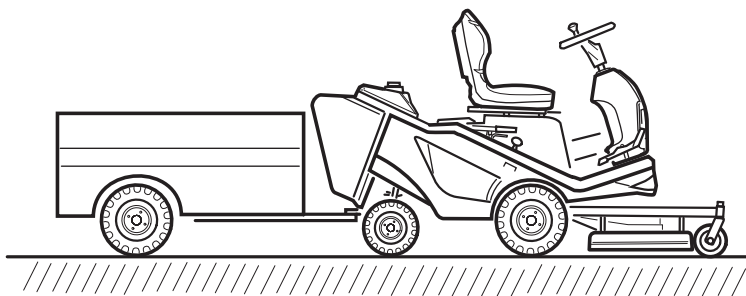

$A + B = \text{MAX } 140 \text{ kg}$

$B \leq 30 \text{ kg}$

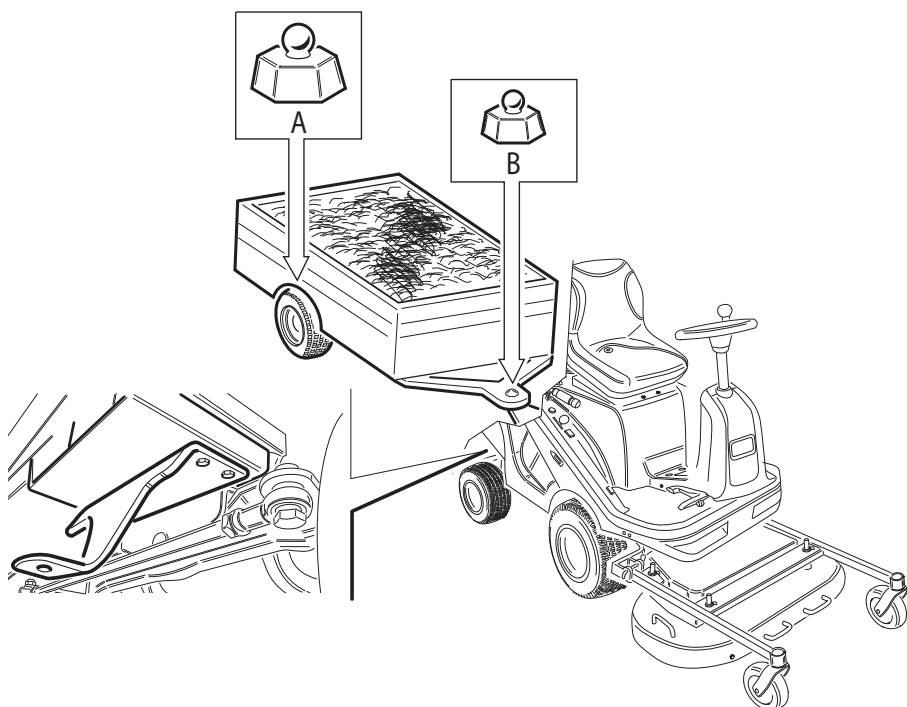

BRIGGS&STRATTON

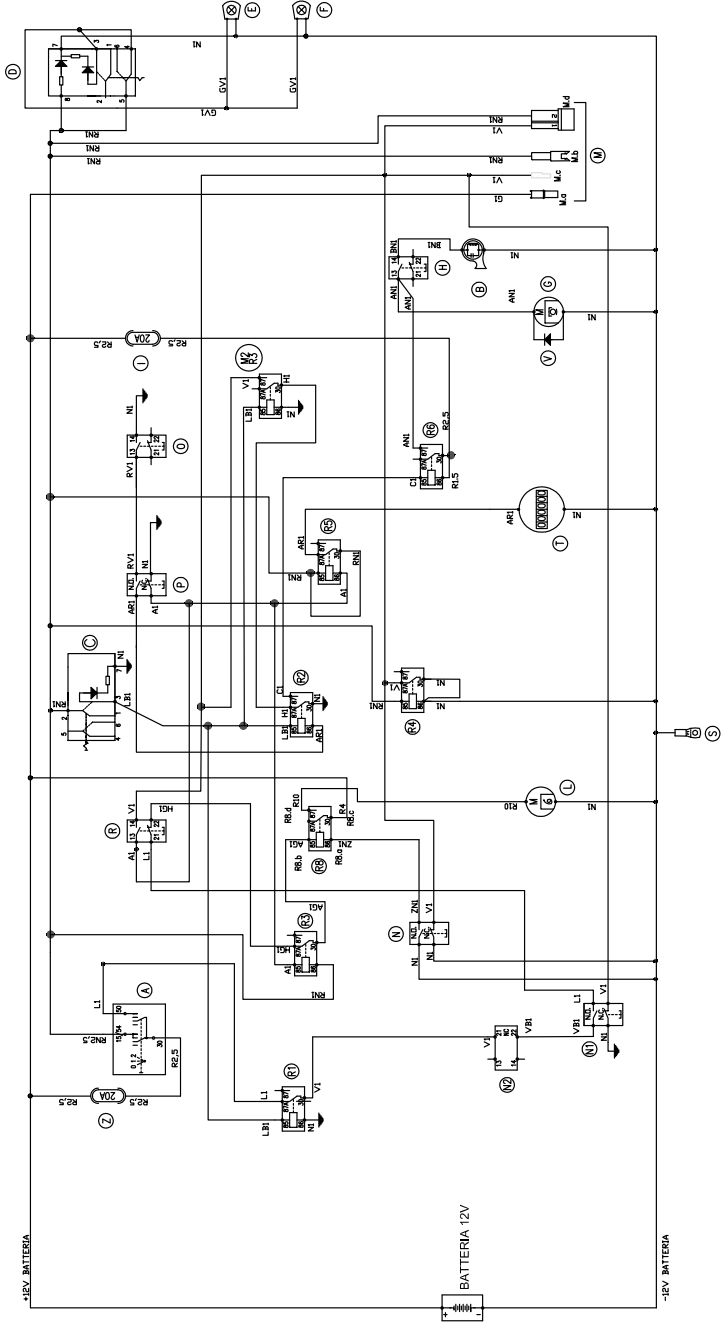

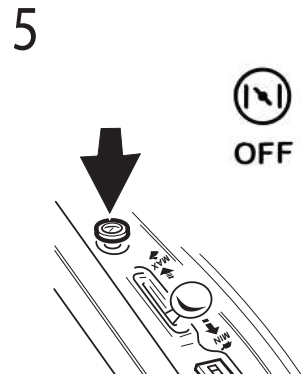
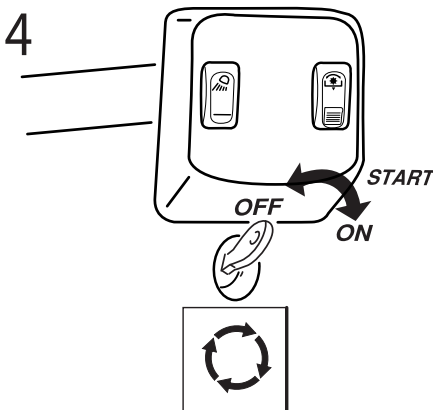
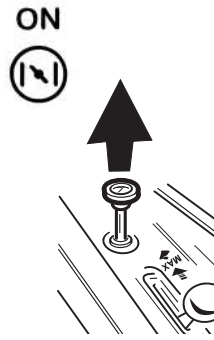
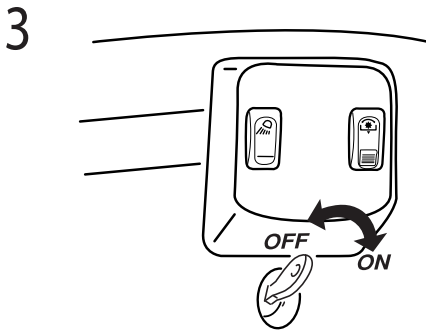
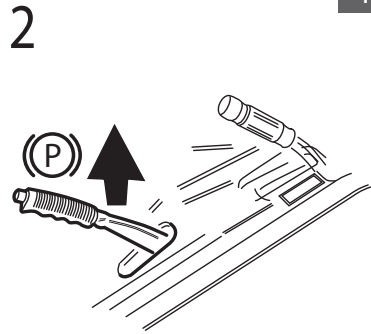

13.

1

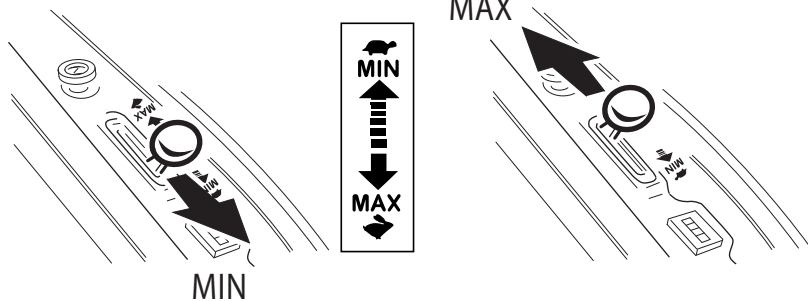

2

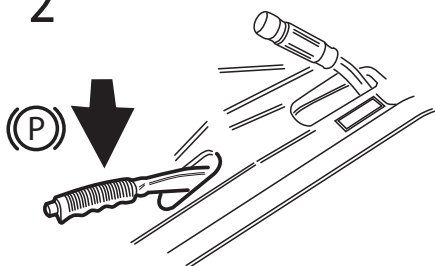

3

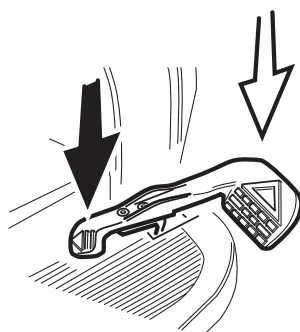

4

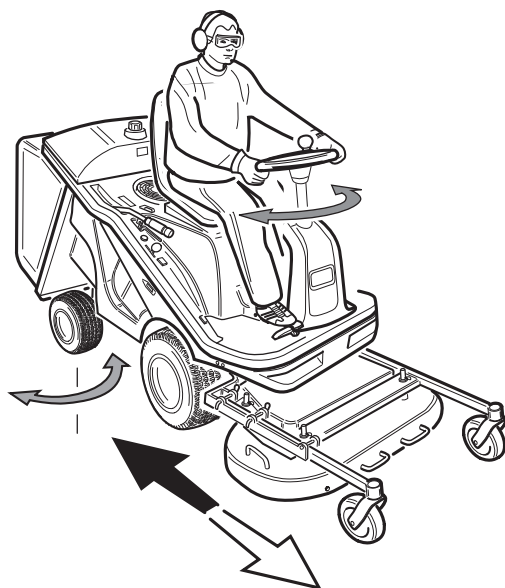

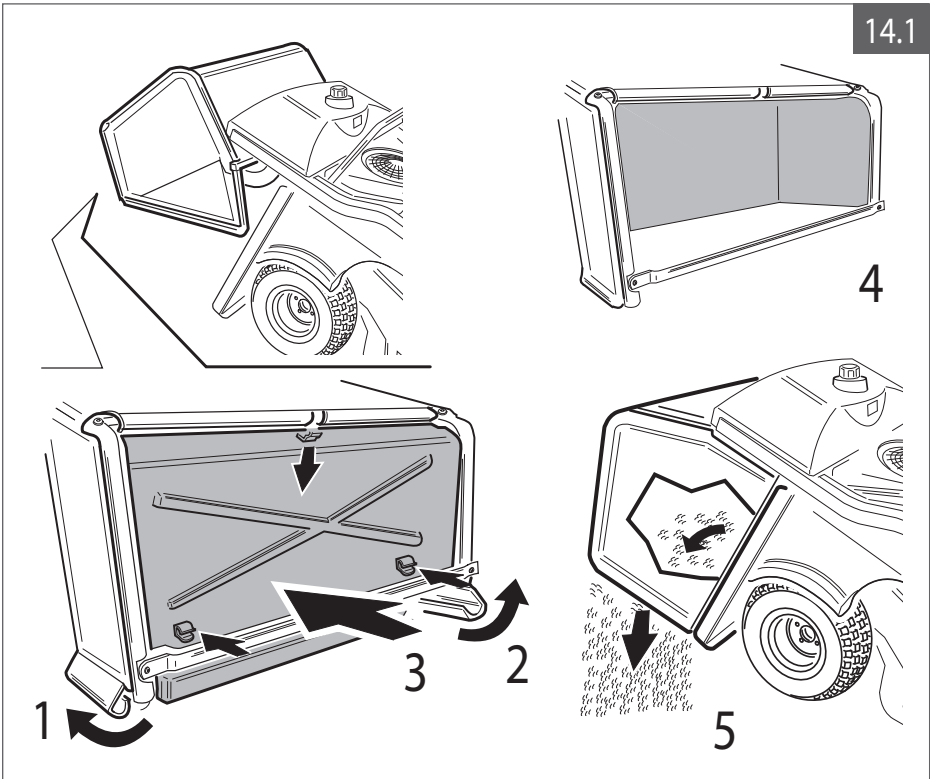
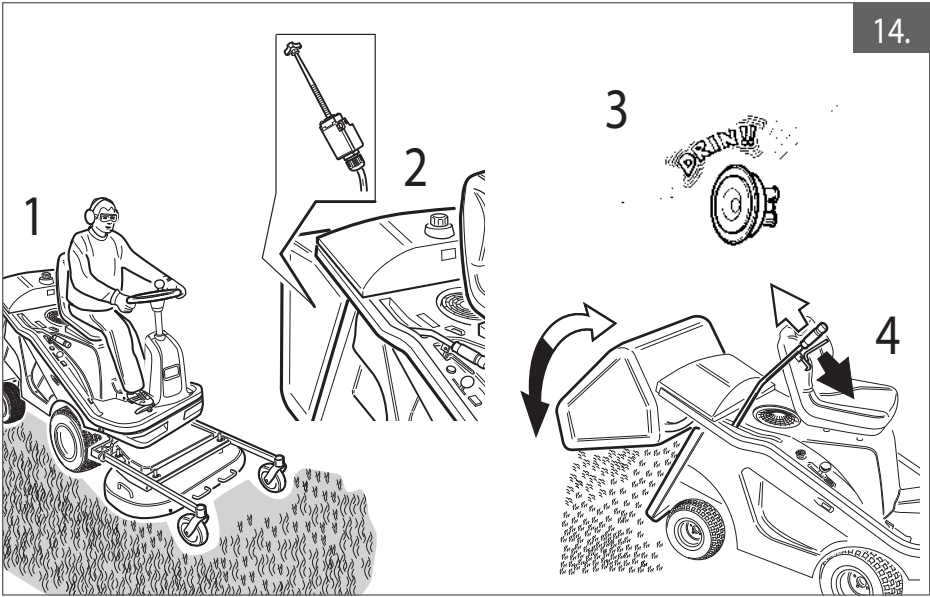

16.

OK

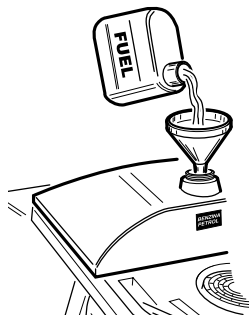

NO !!

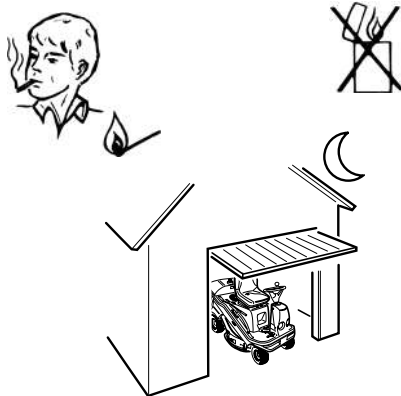

17.1

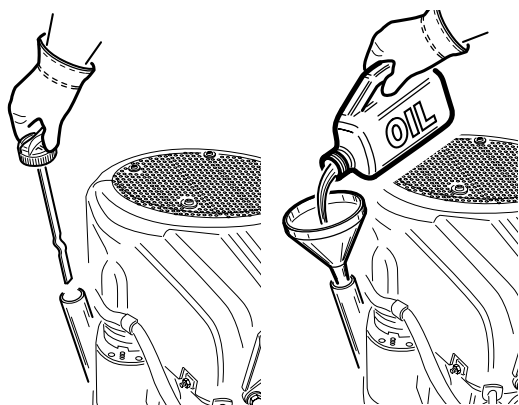

OIL 10W-40

17.2

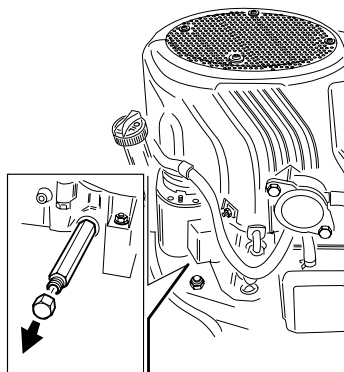

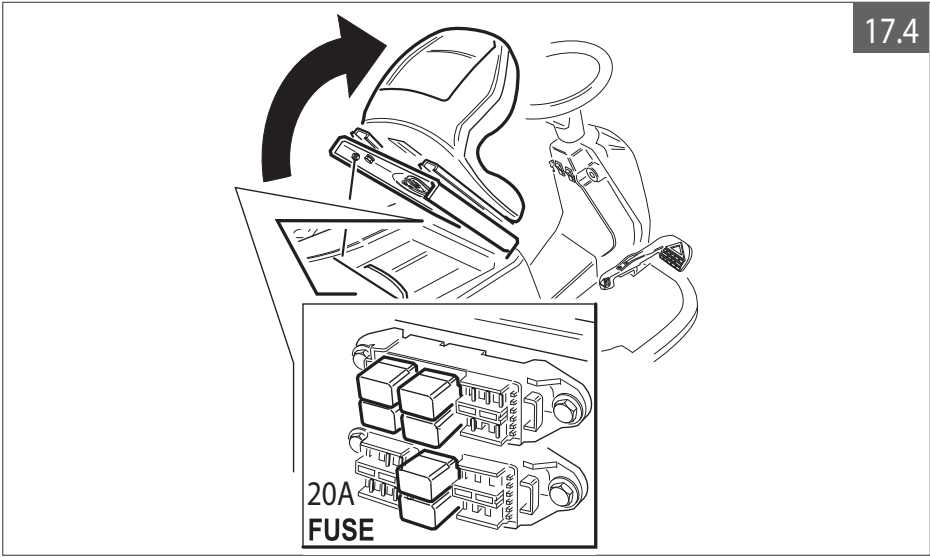
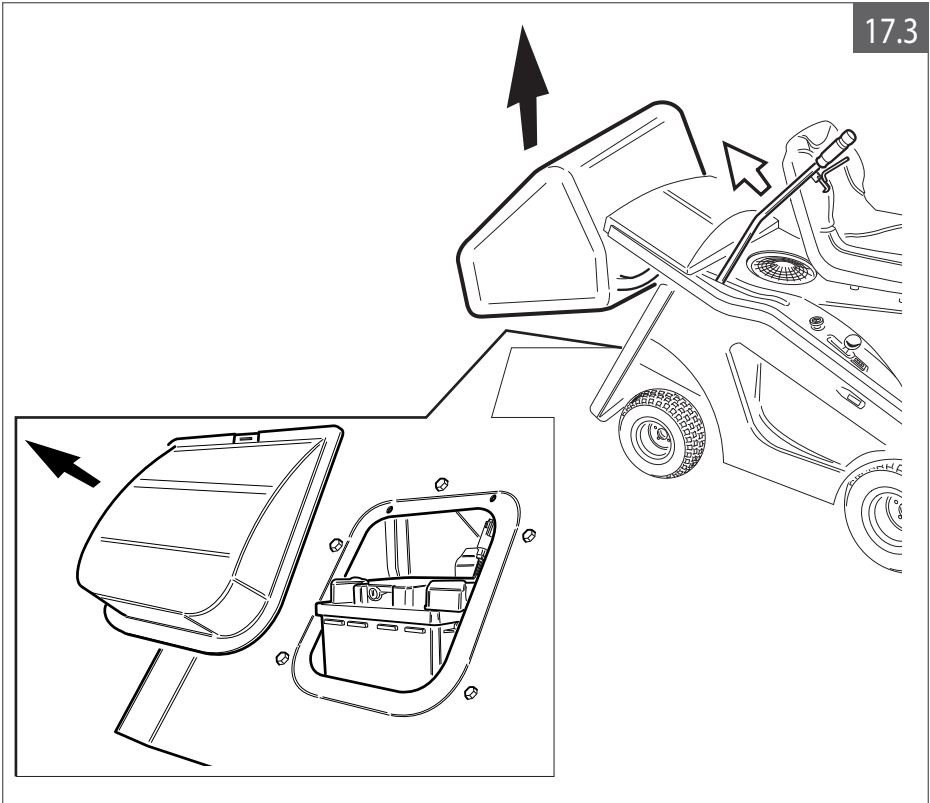

17.5

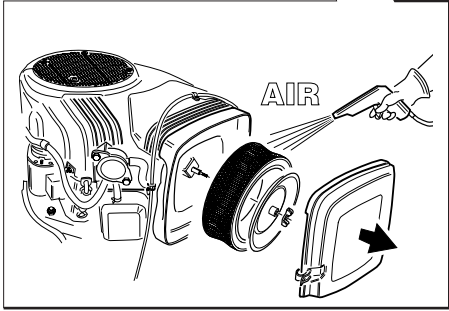

17.6

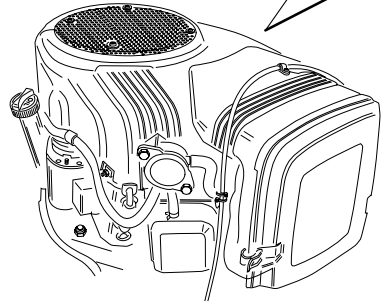
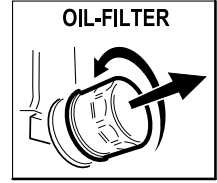

17.7

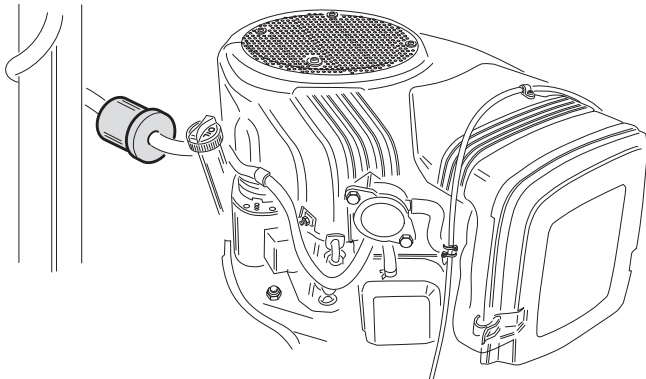

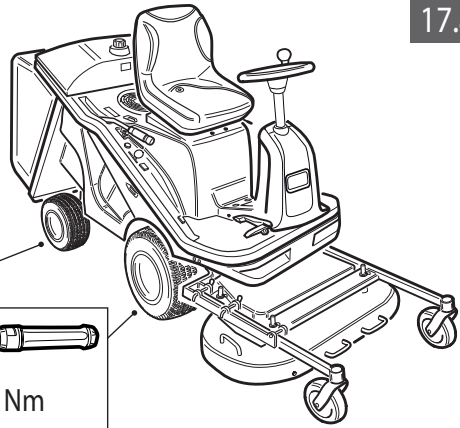

13" - 1,9 bar



16" - 1,4 bar



91 ± 2 Nm

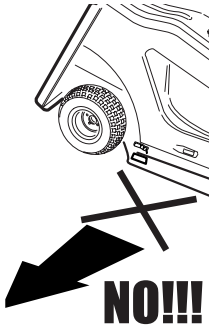

NO!!!

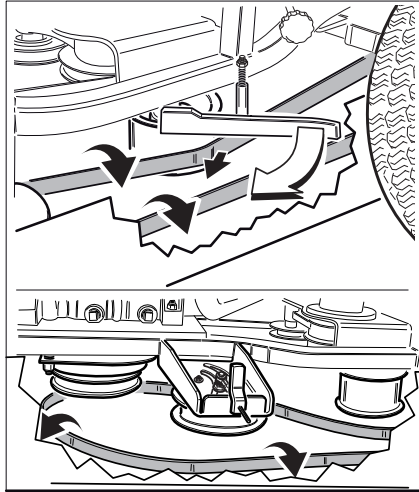

1

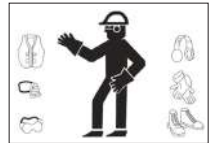
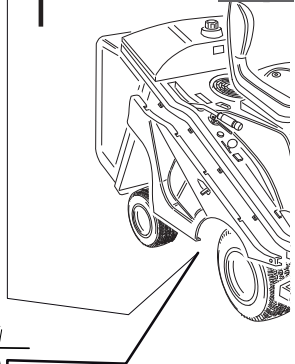

2

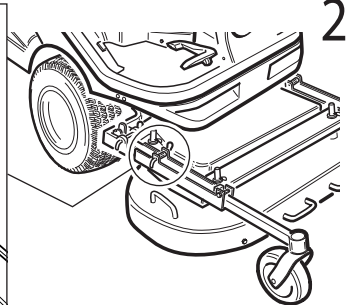
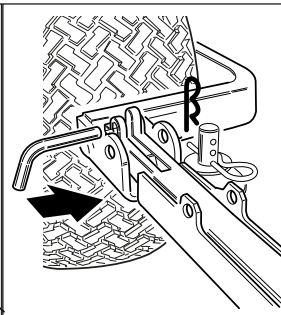
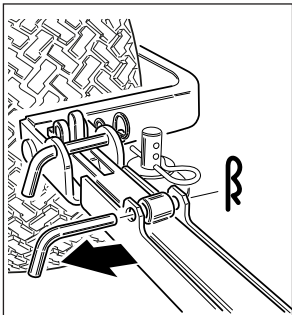

17.9

3

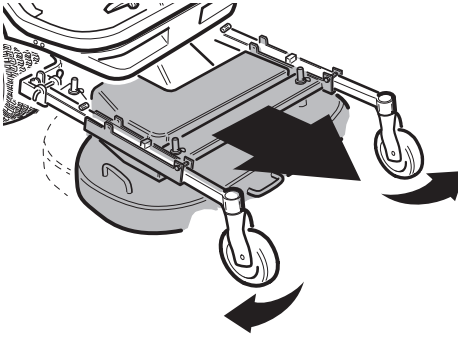

4

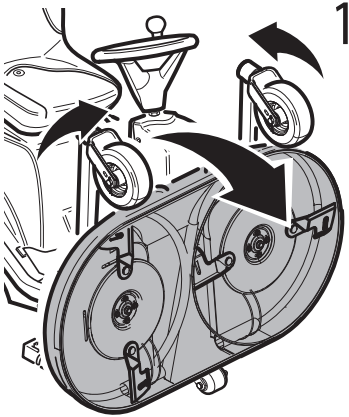
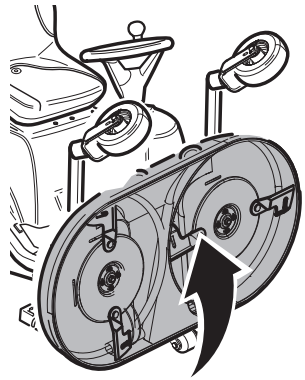

1

2

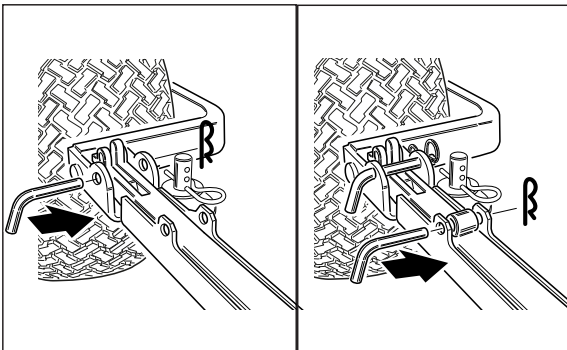
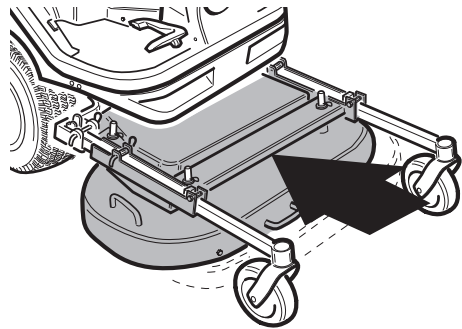

3

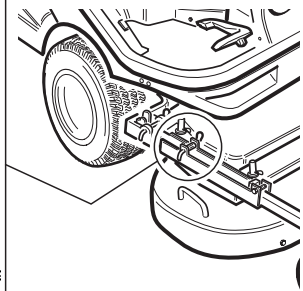

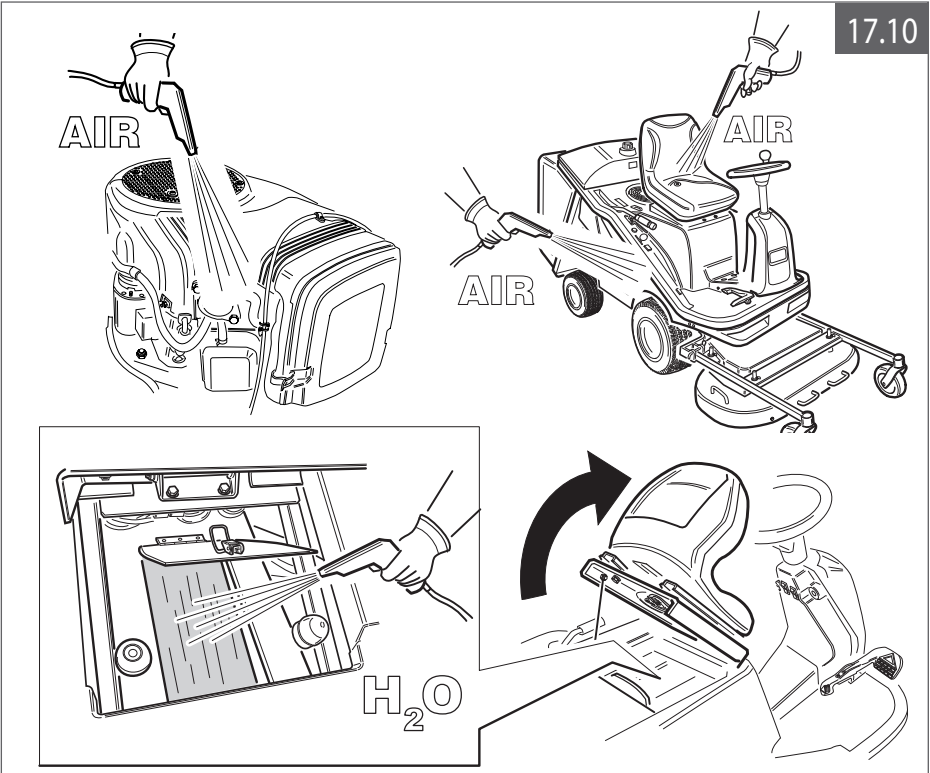
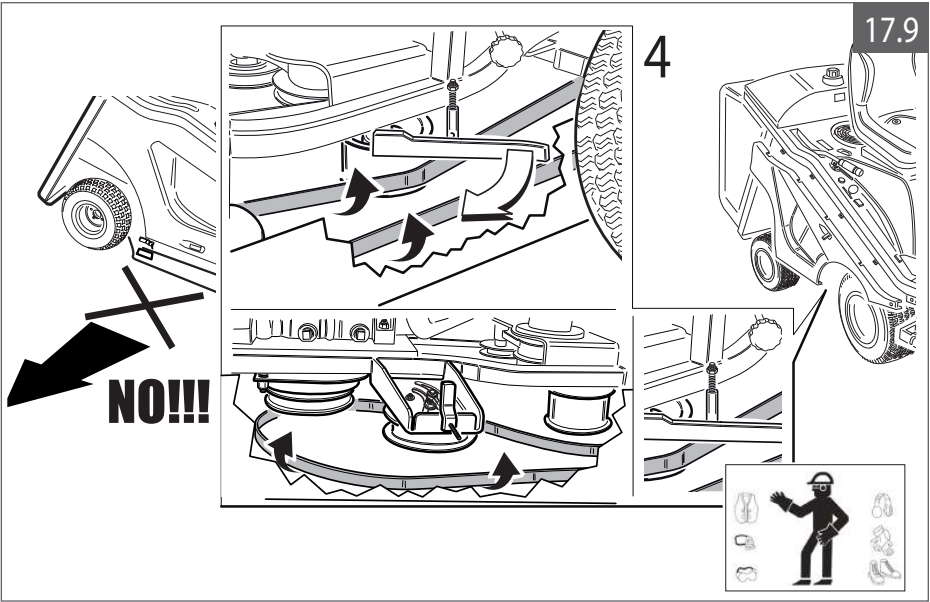

17.10

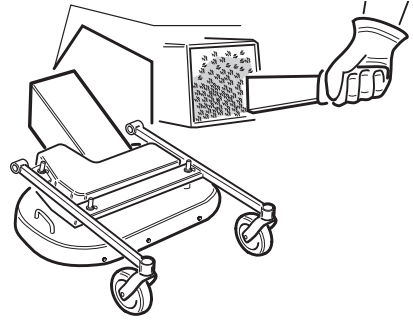
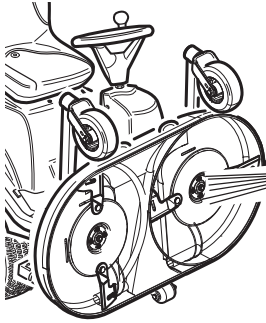

17.11

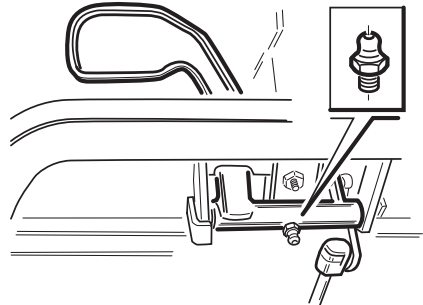
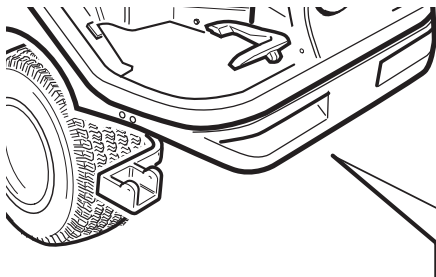
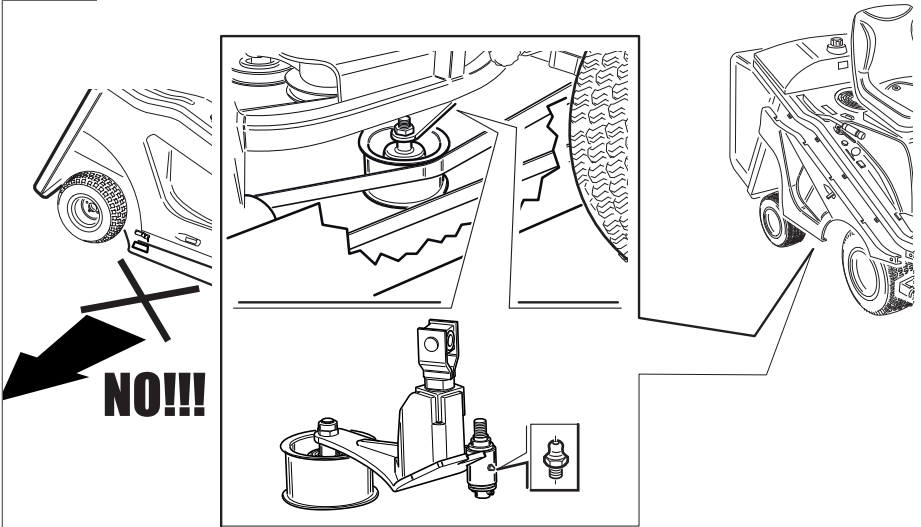

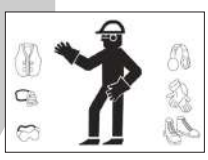
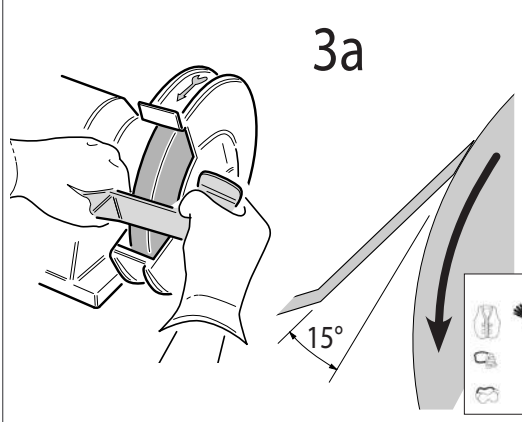
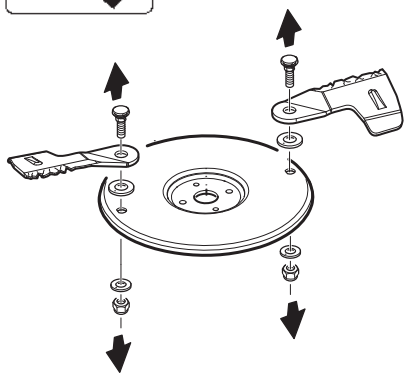
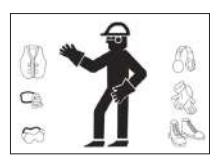
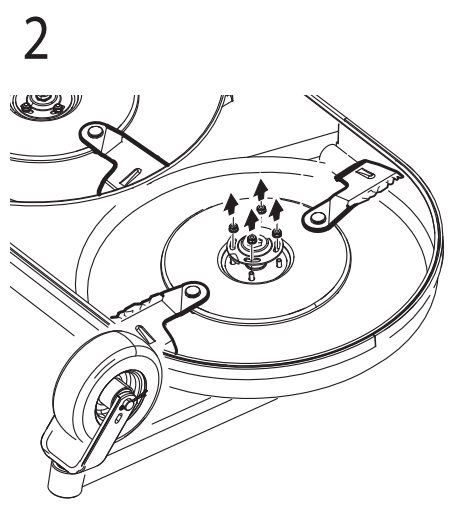
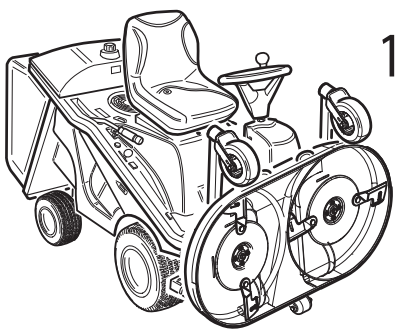

NEW - ORIGINAL

17.12

4

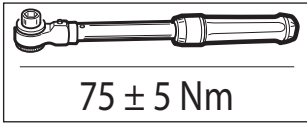
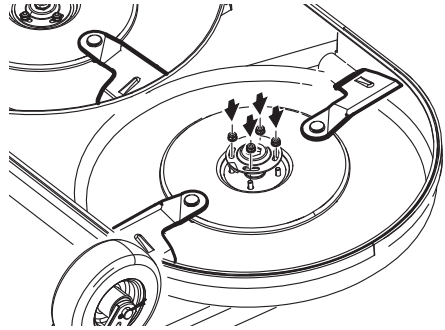
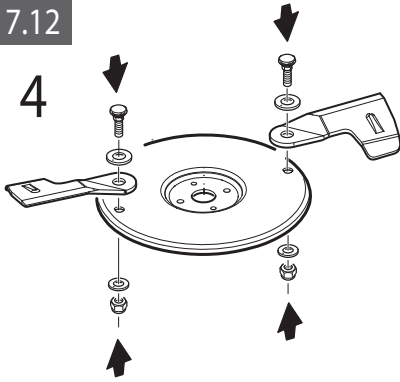

17.13

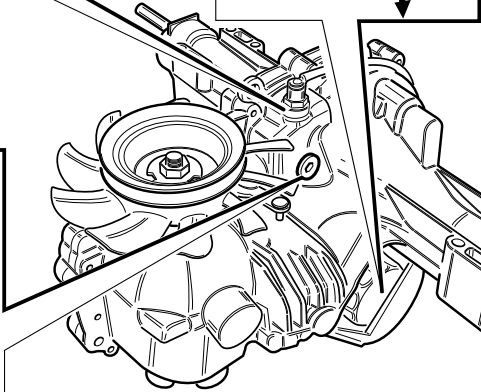
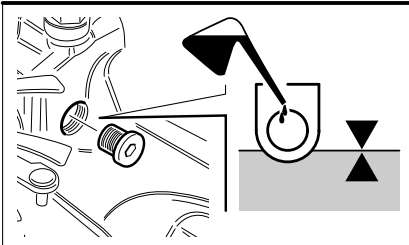
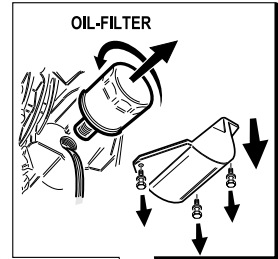

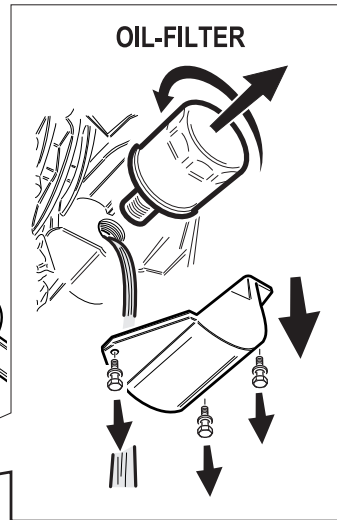
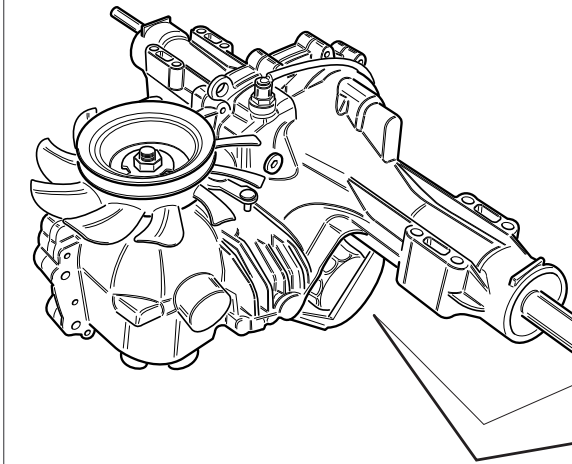

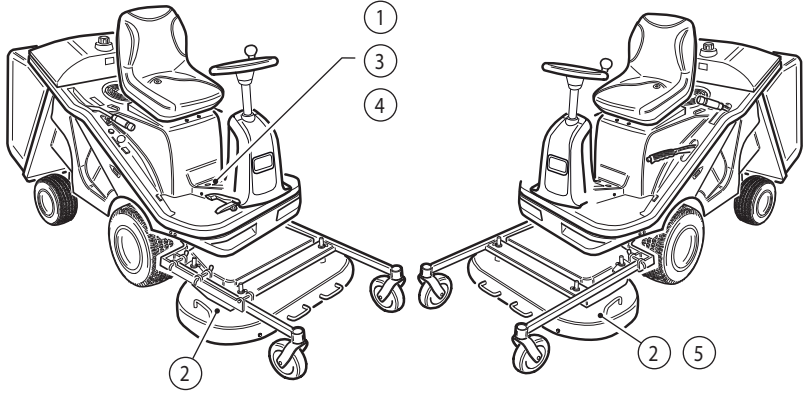

1



2 x2



3



4



5



GENERAL WARRANTY CONDITIONS

The Stiga® product that you have purchased has been designed and manufactured using the latest technology to guarantee quality and reliability for the duration of its working life.

Before delivering this product, your Stiga® Dealer has carried out a series of checks and controls on it, as well as preparing all the information necessary for the correct operation and maintenance of the machine.

Before handing the machine over, the Dealer:

- preforms the various checks, tests and adjustments necessary to prepare the machine for use;
- checks the level of the various oils and liquids;
- hands over the operating manual and the certificate of conformity;
- hands over the documentation relating to the engine;
- demonstrates the machine functions;
- demonstrates the operation of the safety devices/systems;
- explains the importance of observing the routine maintenance program;
- outlines the general warranty conditions.

1. DURATION OF THE WARRANTY

The terms of the Manufacturer's warranty do not affect the rights of the Buyer with regard to the Seller (Dealer) in any way and are to be intended as supplementary to those offered by the Seller (Dealer) within the ambit of the sales contract. Without prejudice for the warranties provided for by the locally applicable legislation, and unless the law stipulates a longer period, Stiga guarantees the product for a period of:

- 2 years, in the case of private users (consumers);
- 1 year, in all other cases.

A private user (consumer) is defined as any individual who uses the product for personal rather than commercial or professional purposes.

The engine is covered by a separate guarantee, described in the documentation it is supplied with. The guarantee covering the engine (and its components) is the sole responsibility of the engine manufacturer's Customer Service organisation.

2. WARRANTY COVERAGE

During the period covered by the terms of the warranty Stiga undertakes, through its Dealer, to repair or replace any part that its technical staff acknowledge as being faulty, by reason of manufacture or material, free of charge. The duration of any such repair or replacement operations shall not prolong or renew the warranty period. The warranty covers the product only if it has been used in as described in the operating manual and maintenance manual supplied with it.

3. LIMITATIONS TO THE WARRANTY

The terms of the warranty shall not apply if the fault is caused by:

- carelessness;
- misuse or unauthorised use;
- mistreatment;
- failure to observe the maintenance procedures and intervals set out in the operating and maintenance manual;
- accidents;
- use of non-original spare parts;
- modifications not authorised by Stiga.

The terms of the warranty shall not cover damage resulting from collisions or the presence of stones or foreign bodies in the working area.

Consumables such as filters, oil, spark plugs, tyres, belts, blades etc. are excluded from the terms of the warranty.

INDEX

NOTES ON DISPOSAL OF THE PRODUCT VALID WITHIN THE EUROPEAN COMMUNITY	27
0. CE LABEL.....	27
1. SERIAL NUMBER.....	27
2. TO OUR CUSTOMERS	27
3. INTENDED USE.....	27
4. REASONABLY FORESEEABLE MISUSE	27
5. OPERATOR'S RESPONSIBILITIES	28
6. SAFETY REGULATIONS.....	28
6.1 SLOPES.....	29
6.2 TRANSPORTING AND UNLOADING.....	29
7. TECHNICAL SPECIFICATIONS	30
7.1 MACHINE WEIGHT.....	30
7.2 COMPATIBLE ACCESSORIES.....	30
7.3 NOISE	30
7.4 VIBRATION.....	30
8. CONTROLS AND INSTRUMENTS	30
9. ASSEMBLING THE EQUIPMENT.....	31
9.1 MOUNTING THE CUTTING DECK.....	31
9.2 MOUNTING THE ATTACHMENTS.....	31
9.3 MOUNTING THE SEAT	31
10. USING THE CONTROLS AND INSTRUMENTS	31
10.1 FORWARD - REVERSE MOTION.....	31
10.2 HAND BRAKE.....	31
10.3 BY-PASS.....	31
10.4 HAND THROTTLE.....	31
10.5 POWER TAKE-OFF (PTO).....	31
10.6 RAISING THE CUTTING DECK.....	31
10.7 TIPPING THE BASKET	31
10.8 FUEL COCK.....	31
10.9 ADJUST THE CUTTING HEIGHT.....	31
10.10 TOWING HOOK.....	31
11. ELECTRICAL CIRCUIT DIAGRAM	31
11.0 KEY TO COLOURS	31
11.1 BRIGGS & STRATTON.....	32
12. STARTING THE ENGINE	32
13. MANOEUVRING THE MACHINE.....	32
14. CUTTING GRASS.....	32
14.1 REAR GRASS DUMPING	32
15. STOPPING THE ENGINE	32
16. REFUELLING	32
17. ROUTINE MAINTENANCE	33
17.1 TOPPING UP THE ENGINE OIL	33
17.2 DRAINING THE ENGINE OIL.....	33
17.3 BATTERY.....	33
17.4 FUSES.....	33
17.5 AIR FILTER.....	33
17.6 ENGINE OIL FILTER.....	33
17.7 FUEL FILTER	33
17.8 TYRE PRESSURE.....	33
17.9 VERTICAL DECK KIT	33
17.10 CLEANING THE MACHINE.....	33
17.11 LUBRICATION	33
17.12 REPLACING AND/OR SERVICING THE BLADES	33
17.13 CHANGING THE TRANSAXLE OIL	33
17.14 TRANSAXLE FILTER.....	33
18. EXTRAORDINARY MAINTENANCE	33
19. PROLONGED INACTIVITY	33
20. SAFETY LABELS	34
21. GENERAL NOTES	34
22. MAINTENANCE TABLE.....	34
23. TROUBLESHOOTING TABLE	34

NOTES ON DISPOSAL OF THE PRODUCT VALID WITHIN THE EUROPEAN COMMUNITY



The product must not be disposed of as solid urban waste but handed over to an authorised collection centre for disposal. If the product is abandoned it could cause significant damage to the surrounding environment. If the product contains batteries they must be removed before disposing of it. Batteries must be disposed of separately in other containers since they contain high toxic substances. The symbol in the figure represents an urban refuse collection bin and indicates that the equipment MUST NOT be disposed of in such containers.

0. CE LABEL

See figure 0.

This label is purely indicative, for the specific information refer to the label placed on your machine.

- | | | |
|----------------------------|--|------------------------|
| 1) Manufacturer's address; | 4) CE Conformity marking | 7) Year of manufacture |
| 2) Type of machine | 5) Weight in kg (with fuel tank empty) | 8) Serial number |
| 3) Acoustic power level | 6) Engine operating power and speed | 9) Article code |

1. SERIAL NUMBER

See figure 1.

2. TO OUR CUSTOMERS

- We are proud to number you among our customers.

- Before starting the machine, the operator must read this manual carefully in order to gain a good understanding of the product and the operating and maintenance instructions it provides.

The MPV vehicles may be fitted with a range of different accessories; for this reason, in addition to this manual, the operator must also study the documentation supplied with the various devices he/she intends to use with the vehicle.

- The machines have been designed and built to produce the best results in a wide range of conditions; naturally, the performance of the vehicle depends on the routine maintenance operations being carried out correctly.

- For specific information and operating instructions not included in this handbook, contact your Dealer who will be pleased to answer all your questions regarding the use and maintenance of this machine.



THIS SYMBOL IS USED TO DRAW YOUR ATTENTION TO THE SAFETY PRECAUTIONS THAT MUST BE IMPLEMENTED BY THE OPERATOR IN ORDER TO PREVENT ACCIDENTS. WHENEVER YOU SEE THIS SYMBOL PROCEED WITH CARE IN ORDER TO PROTECT YOUR SAFETY, AND THAT OF OTHERS.

3. INTENDED USE

This machine is a gardening tool designed to be operated as a front cutting, ride-on lawn mower with seated operator. This machine is intended for use by consumers, i.e. non-professional operators. This machine is intended for "DIY" use only. It is intended for the following uses, among others:

- Cutting deck with rear dumping
- Cutting deck with mulching
- Rear grass dumping
- Snow plough
- Front sweeper

The Company declines all and any responsibility for the consequences if the machine is used with attachments or accessories other than those indicated in this manual. Use part and attachments designed specifically by the Company for use on the model that you have purchased only.

4. REASONABLY FORESEEABLE MISUSE

All uses not indicated in the paragraph "INTENDED USE" are to be considered unauthorised use or misuse.

The use of accessories not indicated in this manual shall be considered misuse and hazardous, since they are not covered by our risk analysis.

The machine must not be used to transport persons (other than the operator), animals or other objects.

Never attempt to operate the machine if you haven't read this handbook first.

Do not attempt to transform or modify the machine in any way not described in this handbook.

The machine should never be operated unless it is in perfect order, always carry out the recommended check and maintenance operations before using it.

Do not allow children and adolescents to operate the machine.

Do not use the machine when barefoot or wearing sandals.

Never use the machine to lift or transport loads.

Never switch the motor on in closed or poorly ventilated spaces. The exhaust gases are toxic.

Keep naked flames and sparks away from the fuel and battery.

Never park the machine on a slope.

Under no circumstances may the machine be operated without the correct accessories and attachments mounted.

Do not tamper with the machine speed control seals.

Do not use the machine in poor weather conditions, especially during thunderstorms.

5. OPERATOR'S RESPONSIBILITIES

It is the responsibility of the operator to read this manual attentively and make sure that he/she has understood the correct machine operating, lubrication and maintenance procedures.

The operator shall be responsible for monitoring the condition of the machine and replacing and repairing those parts of the machine that are subject to continuous wear and tear, and which may constitute a risk for third parties.

The operator shall be responsible for any damage caused to third parties, to him/herself or to property resulting from misuse of the machine or any use that does not comply with the instructions provided in this manual.

The machine must be used and serviced exclusively by persons who are aware of its technical specifications and who understand the applicable safety regulations.

Never allow children or adolescents to operate the machine. Local regulations may establish a minimum age limit for operators.

Use joints, couplings, part and attachments designed and supplied by the Company specifically for use on the model that you have purchased only. For more information, contact your local Dealer.

Do not attempt to transform or modify the machine in any way not described in this handbook.

WHEN USING THE MACHINE, THE OPERATOR MUST ADHERE SCRUPULOUSLY TO THE SAFETY REGULATIONS INDICATED IN THIS HANDBOOK, THE APPLICABLE SAFETY REGULATIONS, ANY OTHER GENERAL SAFETY REGULATIONS, AND THE PROVISIONS FOR HEALTH AND SAFETY IN THE WORKPLACE.

6. SAFETY REGULATIONS

THE BEST OPERATOR IS A CAREFUL OPERATOR

Many accidents may be prevented by observing the precautions described in this handbook.

GENERAL PART

- 1) Read this manual thoroughly and attentively. Do not allow persons who have not read and understood this manual to operate the machine.
- 2) Before using it, always inspect the machine and all its parts for malfunctions, loose bolts and screws, blades and other components that are damaged or not secured correctly. The machine should never be operated unless it is in perfect order, always carry out the recommended check and maintenance operations before using it.
- 3) Familiarise yourself with the various machine parts and controls before operating it.
- 4) The machine may only be used by adults who are aware of how to operate it. Do not allow children and adolescents to operate the machine.
Do not use the machine if you are not in good physical condition.
- 5) Ensure persons and objects remain at a safe distance, as described below.
- 6) Use only parts and attachments supplied by the Company and do not permit anyone else to modify or transform the machine in any way. For more information, contact your local Dealer.
- 7) Replace any safety and warning labels that may be damaged, illegible or missing. Check list of safety labels in the corresponding safety section. Keep the labels free from mud, dirt and dust.
- 8) Keep hands, feet and all other body parts away from moving parts.
- 9) Never use the machine if the safety panels and guards are not fitted in their correct positions.
Do not use the machine if the safety devices are not in perfect working order.
Do not tamper with the safety devices for any reason whatsoever.
- 10) If the machine strikes or becomes entangled with an object, stop immediately, deactivate the PTO, switch off the engine, place the equipment on the ground and inspect it thoroughly. Before restarting, ensure the machine has been restored to the optimum working condition.
- 11) When the machine is not in use, deactivate the PTO (Power Take-Off, which operates the cutting device), lower the cutting device until it is resting on the ground, switch the engine off and remove the ignition key.
- 12) Make sure that the machine has been switched off before carrying out any maintenance work on it. Disconnect the battery terminals before working on the electrical system.
- 13) Operate the machine and cutting device at speeds that are compatible with safety requirements and the specifications of the model in use.
- 14) Proceed with extreme care when operating the machine on sloping ground. Reduce speed to a minimum.
- 15) When operating the machine and carrying out maintenance work on it, always wear the appropriate clothing: safety goggles, gloves, and clothing, and protective, slip resistant footwear.
- 16) Use the machine in good conditions of visibility.
- 17) All operators should receive the appropriate professional and practical training before using the machine. Such training should focus on the following aspects in particular:
 - the need to remain attentive and concentrated when using seated operator machinery.
 - the fact that it is not possible to regain control over the machine by using the brakes when it is sliding down a slope.

The main causes leading to loss of control are:

- a) insufficient wheel grip;
 - b) excessive driving speed;
 - c) insufficient braking;
 - d) type of machine not suitable for the work being carried out;
 - e) lack of awareness of the effect of the ground conditions, especially slopes;
 - f) accessories and attachments not connected correctly, and hence poor distribution of loads.
- 18) Always wear long trousers and sturdy footwear when operating the machine. Do not use the machine when barefoot or wearing sandals.
 - 19) Inspect the area where the machine is to be used thoroughly before using it, and remove any objects that may be projected by the machine.
 - 20) Always disengage the PTO when moving the machine.
 - 21) The user must always operate the hand brake when leaving the machine unattended, even momentarily.
 - 22) Take care to avoid objects and above all, people, when reversing.

6.1 SLOPES See figure 6.1

- Do not use the machine on longitudinal slopes having a gradient of greater than 15°.
- Do not use the machine on lateral slopes having a gradient of greater than 10°.
- Do not attempt to negotiate slopes of any nature (longitudinal or lateral) with the deck and basket raised.
- Do not stop or start the machine suddenly while it is positioned on an up or down slope.
- Keep the machine speed to a minimum when negotiating slopes or tight curves.
- Take care of any bumps, holes or other hidden dangers. The machine may tip over more easily on uneven ground.
- Do not use the machine in the vicinity of verges, ditches or embankments; the machine may tip over unexpectedly if one of its wheels goes over the edge, or the verge subsides.

6.2 TRANSPORTING AND UNLOADING See figure 6.2

The machine is heavy and can cause serious crushing damage.

Load and unload carefully using ramps.

Used an approved trailer when transporting the machine. During transport, make sure that the hand brake is on, and secure the machine using approved devices such as belts, chains or cables.

N.B.: If the machine is in its packaging and positioned on its pallets, it may be moved using a fork-lift truck.

MINIMUM WEIGHT CAPACITY 440 Kg



IMPORTANT:

The hand brake alone is not sufficient to secure the machine during transport. Secure the machine to the vehicle using approved devices.

7. TECHNICAL SPECIFICATIONS See figure 7.

Type	FMC 112	
Model	MPV 320W	MPV 520W
Engine	Vanguard 16 V-Twin (305777)	Vanguard 21 V-Twin (385777)
Engine revolutions (min ⁻¹)	2400	2400
Power (kW)	7.75	10.84
Displacement (cm ³)	480	627
N.of cylinders	2	2
Spark plug	Champion XC12YC	
Drive wheels	Front	
Type of transmission	Hydrostatic	
Service brake	Hydrostatic	
Hand brake	Mechanical, disk	
Max. speed (Km/h)	7	
Fuel tank capacity (L)	19	
Blades	RH - 87001000014	LH - 87001000013
Mulching blades	RH - 2655	LH - 2658
Spare part number	RH - 118830014/0	LH - 118830015/0
Blade rotation	Rotation controlled by electromagnetic clutch	
Cutting height adjustment (cm)	2 ÷ 8	
Effective cutting width (mm)	1120	

7.1 MACHINE WEIGHT

Model	Mass with empty fuel tank (kg)
MPV 320W	387
MPV 520W	387

7.2 COMPATIBLE ACCESSORIES

- Snow blade: SNB 1601
- Front sweeper: SWR 1603
- Grass cutter deck 112 C

7.3 NOISE

Acoustic power level	100 dB (A) ± 0.7
Acoustic pressure operator's position	83 dB (A) ± 1.89
Guaranteed sound power level	100 dB (A)

7.4 VIBRATION

- Vibration of upper members: 2 m/s² ± 0.85
- Vibration of machine body:.....0.7 m/s² ± 0.21

8. CONTROLS AND INSTRUMENTS See figure 8.

The machine driving system consists of the following controls:

- | | | |
|---------------------------------|------------------------------------|---------------------------------|
| 1) Steering wheel | 7) Engage PTO control | 13) Forward - reverse pedal |
| 2) Hand brake | 8) Throttle lever | 14) Starter |
| 3) Seat position adjustment | 9) Lever for raising the equipment | 15) Timer |
| 4) By-Pass | 10) Light switch | 16) Tunnel cleaning compartment |
| 5) Cutting height adjustment | 11) Ignition key | |
| 6) Lever for opening the basket | 12) Fuel cock | |

9. ASSEMBLING THE EQUIPMENT

9.1 MOUNTING THE CUTTING DECK See figure 9.1

- 1) Attach the machine lifting arms to the couplings on the equipment.
- 2) Insert the safety pins and the associated retaining clips.
- 3) Loosen the belt tensioner
- 4) Fit the belt.

9.2 MOUNTING THE ATTACHMENTS See figure 9.2

When mounting the attachments, consult the specific mounting guide supplied with the specific attachment.

9.3 MOUNTING THE SEAT See figure 9.3

- 1) The seat is supplied with the upper guides already mounted.
- 2) Connect the seat micro-switch to the electrical system connector.
- 3) Slide the seat into place from the front of the machine, using the guides mounted on the deck.
- 4) Screw the front end stop screw into place.

10. USING THE CONTROLS AND INSTRUMENTS

10.1 FORWARD - REVERSE MOTION See figure 10.1

10.2 HAND BRAKE See figure 10.2

10.3 BY-PASS See figure 10.3



WARNING:

Avoid towing the machine over long distances when the by-pass is activated.

10.4 HAND THROTTLE See figure 10.4

10.5 POWER TAKE-OFF (PTO) See figure 10.5

- 1) In order to engage the PTO, push the red safety tab upwards and press the button at the same time.
- 2) To enable the PTO, press the button again.

10.6 RAISING THE CUTTING DECK See figure 10.6

Pay attention to possible crushing hazards, use the lifting handles provided.

10.7 TIPPING THE BASKET See figure 10.7

10.8 FUEL COCK See figure 10.8

10.9 ADJUST THE CUTTING HEIGHT See figure 10.9

10.10 TOWING HOOK See figure 10.10

11. ELECTRICAL CIRCUIT DIAGRAM

11.0 KEY TO COLOURS

A	Light blue	H	Grey	R	Red
B	White	L	Blue	S	Pink
C	Orange	M	Brown	V	Green
G	Yellow	N	Black	Z	Purple

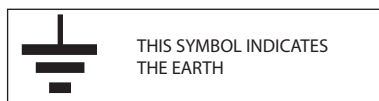

11.1 BRIGGS & STRATTON See figure 11.1

REF.	Description
A	Ignition switch
B	Basket full warning buzzer
C	PTO switch
D	Working lights switch
E	Working light
F	Working light
G	PTO clutch
H	Basket full micro-switch
L	Starter motor
M	Engine connections
N	Bonnet closed micro-switch
N1	Left side safety micro-switch
N2	Accelerator pedal safety micro-switch
O	Basket closed micro-switch

P	Seat micro-switch
R	Hand brake micro-switch
R1	Enable PTO start relay
R2	PTO safety relays
R3	Enable start from safety devices relay
R4	Stop engine using key relay
R5	Timer relay
R6	PTO relay
R7	Stop engine from safety devices relay
S	System earth
T	Timer
V	Suppressor diode on PTO clutch
Y	PTO fuse
Z	System protection fuse
R8	Ignition contactor switch

12. STARTING THE ENGINE See figure 12.

- 1) Assume the correct position in the operator's seat.
- 2) Make sure that the hand brake is fully engaged.
- 3) Insert the choke when starting the engine from cold and turn the ignition key to the "ON" position.
- 4) Turn the ignition key towards the engine starting symbol.
- 5) Once the engine is running, release the choke slowly.

13. MANOEUVRING THE MACHINE See figure 13.

- 1) Regulate the accelerator lever.
- 2) Release the hand brake.
- 3) Select the desired speed using the pedal positioned on the right hand side of the machine.
- 4) Use the steering wheel to control the front wheels.

N.B.: To stop the machine, simply take your foot of the forward - reverse pedal; once it is stationary, engage the hand brake.



WARNING: Drive slowly until you have familiar with the vehicle. Ensure people and animals remain at a distance of at least 3 m.

14. CUTTING GRASS See figure 14.

14.1 REAR GRASS DUMPING See figure 14.1

15. STOPPING THE ENGINE

- 1) Stop the machine.
- 2) Disengage the PTO
- 3) Engage the hand brake.
- 4) Set the engine to idling speed.
- 5) Rotate the ignition key from the "ON" position to the "STOP" position.

16. REFUELLING See figure 16.

The machine must be refuelled in open or well-ventilated spaces, with the engine switched off and away from sparks or naked flames. Make sure that you are using the correct type of fuel.

WARNING: THE FUEL IS HIGHLY INFLAMMABLE.

STORE FUEL IN SUITABLE CONTAINERS. ONLY REFUEL THE MACHINE OUTDOORS, AND DO NOT SMOKE WHILE CARRYING OUT SUCH OPERATIONS. TOP UP WITH FUEL BEFORE STARTING THE ENGINE. NEVER REMOVE THE FILLER CAP OR ATTEMPT TO REFUEL THE MACHINE WHILE THE ENGINE IS RUNNING OR WHEN IT IS HOT.

In the case of fuel leaks, do not attempt to start the engine, but move the machine away from area where the leak occurred, taking care not to create ignition sources until all the vapour has dissipated. Replace fuel tank and container caps correctly.

Never store the machine with fuel in tank inside buildings where the vapour could come into contact with sparks or naked flames. Allow the engine to cool before storing the vehicle in any enclosed space.

17. ROUTINE MAINTENANCE

Whenever it is necessary to carry out maintenance operations, always use original spare parts in order to guarantee maximum reliability.

Before carrying out any maintenance work, read the instructions provided in paragraph 6 "Safety Regulations". Check that all the machine commands and controls function correctly at regular intervals.

17.1 TOPPING UP THE ENGINE OIL See figure 17.1

• BRIGGS & STRATTON

Consult the operating and maintenance manual supplied with the engine.

OIL 10W-40

17.2 DRAINING THE ENGINE OIL See figure 17.2

17.3 BATTERY See figure 17.3

It is not necessary to check or top-up the battery fluid.

17.4 FUSES See figure 17.4

17.5 AIR FILTER See figure 17.5

Regular checks.

17.6 ENGINE OIL FILTER See figure 17.6

Consult the operating and maintenance manual supplied with the engine.

17.7 FUEL FILTER See figure 17.7

17.8 TYRE PRESSURE See figure 17.8

If the front tyres are inflated to different pressures the blades will cut the grass at different heights.

17.9 VERTICAL DECK KIT See figure 17.9

17.10 CLEANING THE MACHINE See figure 17.10

17.11 LUBRICATION See figure 17.11

See maintenance table

17.12 REPLACING AND/OR SERVICING THE BLADES See figure 17.12

17.13 CHANGING THE TRANSAXLE OIL See figure 17.13

- 20W-50 Oil

17.14 TRANSAXLE FILTER See figure 17.14

18. EXTRAORDINARY MAINTENANCE

Extraordinary maintenance operations may only be carried out by an authorised service workshop.

19. PROLONGED INACTIVITY

If the MPV is unused for prolonged periods, it is necessary to carry out the following operations in order to ensure it continues to function correctly the next time it is used, and to prolong its working life:

- Follow all the instructions provided in the operating and maintenance manual supplied with the engine in order to take it "out of service".
- Remove the battery, recharge it and store it in dry, well-ventilated.
- Clean the engine carefully, taking care to remove any incrustations caused by build ups of soil and grass.
- Carry out the "routine maintenance" operations described above and, if necessary, the "extraordinary maintenance" procedure.
- Park the machine in a dry, well-ventilated place, covering it with a waterproof protective sheet.
- While the machine is not in use, make sure that the tyres are inflated to the indicated pressure, and move the vehicle at regular intervals so that the same section of the tyres is not always in contact with the ground.
- Empty the fuel tank.
- Close the fuel cock.

20. SAFETY LABELS

See figure 20.

Description of safety labels

Label n.1 indicates:

- General hazard warning;
- Danger of objects being ejected during operation;
- Read the instruction manual carefully,
- Remain at a safe distance from the machine while it is operating;
- Tipping hazard on lateral slopes having a gradient of greater than 10°;
- Tipping hazard on longitudinal slopes having a gradient of greater than 15°;

Label n.2 indicates:

Cutting hazard for fingers and feet.

Label n.3 indicates:

Safety goggles obligatory.

Label n.4 indicates:

Ear defenders obligatory.

Label n.5 indicates:







Grass cutter deck weight.

21. GENERAL NOTES

A) For any service activities not covered by the following manual, contact an authorised service centre

B) Keep the operating and maintenance handbook in a suitable location in order to guarantee it remains in good condition. This manual may be subject to modifications without prior notice, or further obligation, in order to include any variations and modifications to the units that have already been despatched. THIS DOCUMENT may not be reproduced in any way and/or translated, either wholly or partially, without the written permission of the owner.

22. MAINTENANCE TABLE

PRINCIPLE MAINTENANCE OPERATIONS	INITIAL CHECK	INTERVAL					NOTE	FIG.
		DAILY	WEEKLY	EVERY 50 HOURS	EVERY 100 HOURS	EVERY 400 HOURS		
BRIEF GENERAL CLEANING	HOURS	X						17.10
THOROUGH GENERAL CLEANING			X					17.10
LUBRICATION				X				17.11
CLEANING THE AIR FILTER		X+						17.5
ENGINE OIL LEVEL		X						17.1
CHANGING THE ENGINE OIL	5				X			17.2
CHANGING THE ENGINE OIL FILTER CARTRIDGE	5				X			17.6
CHANGING THE FUEL FILTER					X			17.7
CHANGING THE AIR FILTER				X+				17.5
CHANGING THE TRANSAXLE FILTER	75					X		17.14
CHANGING THE TRANSAXLE OIL	75					X		17.13
ENGINE MAINTENANCE								
CHECKING THE CONDITION OF THE BLADES		X+						17.12
Tyre pressure check			X					17.8
CHECKING THE CHAIN TENSIONER SPRING			X					
CHECKING THE WHEEL NUT TIGHTENING TORQUE			X				91±2 Nm	17.8

+

If the machine is used in particularly demanding conditions this check should be carried out more frequently.



Engine maintenance: Consult the operating and maintenance manual supplied with the engine.

23. TROUBLESHOOTING TABLE

If the problem is not listed in this table, contact the authorised dealer.

If the problem persists even after checking all the possible causes listed in the table, contact the authorised dealer.

Engine

PROBLEM	CAUSE/SOLUTION
Poor engine performance	Dirt in the fuel supply system or old fuel, fuel and air filter dirty.
The engine does not start	Operator not in the driving position. Hand brake not engaged Engine bonnet open or not closed correctly. The fuel cock is CLOSED. No fuel, or wrong type of fuel. The fuel filter is clogged. Fault on the electrical system. Refer to the "Electrical System" paragraph in this chapter.
The engine starts with difficulty	Incorrect use of the choke. The fuel filter is clogged. Old or incorrect fuel.
The engine runs irregularly	The choke has not been fully released. The fuel lines or filter are clogged. The fuel is stale or dirty. The fuel injector is clogged The air filter element is clogged Fault on the electrical system. Refer to the "Electrical System" paragraph in this chapter.
the engine misfires under load	The choke has not been fully released. The fuel is stale or dirty. The fuel filter is clogged.
Black smoke from the exhaust pipe	The choke has not been fully released. The air filter element is dirty

Electrical system



PROBLEM	CAUSE/SOLUTION
The starter motor fails to start	Hand brake not engaged. The battery is not charged. The fuse has blown Operator not in the driving position.

MACHINE

PROBLEM	CAUSE/SOLUTION
A the engine is running but the machine fails to move	The transaxle bypass is in the engaged position. Drive belt broken or damaged.

• Soggetto a modifiche senza preavviso • Подлежи на промени без предупреждение • Moguće su promjene bez najave • Možnost změn bez předešlého upozornění • Ret til ændringer forbeholdes • Kann ohne Vorankündigung geändert werden • Υπόκειται σε αλλαγές χωρίς προειδοποίηση • Subject to modifications without notice • Sujeto a modificaciones sin previo aviso • Võimalikud muudatused ilma ette teatamata • Voidaan tehdä muutoksia ilman ennakkoilmoitusta • Sujet à des modifications sans aucun préavis • Podložno promjenama bez prethodne obavijesti • Előzetes értesítés nélkül módosítható • Objekto pakeitimai be perspėjimo • Var tikt mainīts bez iepriekšēja brīdinājuma • Подлежи на промени без претходно известување • Kan zonder kennisgeving wijzigingen ondergaan • Kan endres uten forvarsel • Poddawany modyfikacjom bez awizowania • Sujeito a alterações sem aviso prévio • Poate fi modificat, fără preaviz • Может быть изменено без преомления • Možnosť zmien bez predošlého upozornenia • Lahko pride do sprememb brez predhodnega obvestila • Podložno izmenama bez upozorenja • Kan utsättas för modifieringar utan att detta meddelas • Önceden haber verilmeksizin değiştirilebilir



.....	
Type:	 LWA dB
..... -s/n -Art.N	
	

Manufactured for

STIGA SpA

Via del Lavoro, 6

31033 Castelfranco Veneto (TV) ITALY

Manufactured by

OFFICINE BIEFFEBI S.p.A.,

Via dell'Artigianato, 7 46023 Gonzaga (Mantova) Italy